

Sunfab SL is a series of straight double pumps with extremely low noise levels for demanding mobile hydraulics.

Sunfab SL comes in eight different sizes, where three models feature differentiated flows. Pumps with differentiated flow increase the field of application as they can provide three different flows: one small, one large and one combined flow.

Maximum working pressure depending on the model: 33-35 MPa.

Sunfab SL's slim pump housing makes direct mounting on the power take off possible in very confined areas. SL is also ideal for installation using a frame bracket via an intermediate shaft.

Sunfab SL is available in a version with a Savtec valve for applications where the hydraulics need to be used while the vehicle is on the move.

Sunfab SL's high level of reliability is based on the choice of materials, hardening methods, surface structures and the quality assured manufacturing process.

Other advantages of Sunfab SL

- A cost effective total solution in relation to a conventional installation using two pumps with a splitter gear box
- Large displacement gives the possibility of low motor speeds and low noise levels
- Smooth operation over the entire speed range
- Long life due to high demands on material selection, such as bearings, seals, etc
- O-rings on all contact surfaces as well as double shaft seals eliminate oil leakage from the pump and power take off

Type SL		20/20	28/28	40/20	35/35	56/28	46/46	53/53	64/32
Nominal oil flow at pump speed rpm	500	10+10	14+14	20+10	l/min				
	1000	20+20	28+28	40+20	17.5+17.5	28+14	23+23	26.5+26.5	32+16
	1500	30+30	42+42	60+30	35+35	56+28	46+46	53+53	64+32
Deplacement	cm ³ /rev.	20.3+20.3	27.5+27.5	40.7+20.3	33.9+33.9	54.9+27.5	45.8+45.8	52.5+52.5	63.0+31.5
Max pump speed	rpm	2200	1800	2200	2200	1800	1800	1600	1600
Max working pressure	MPa	35	35	35	33	35	33	33	35
Weight	kg	22.0	22.0	22.0	22.0	22.0	22.0	22.0	22.0
Dimensions	mm A	133	133	133	133	166	166	166	166
	B	50	50	50	50	64	64	64	64
Tare-weight torque	Nm M	26.5	26.5	26.5	26.5	26.5	26.5	26.5	26.5
Direction of rotation	independent								

Subject to design alteration

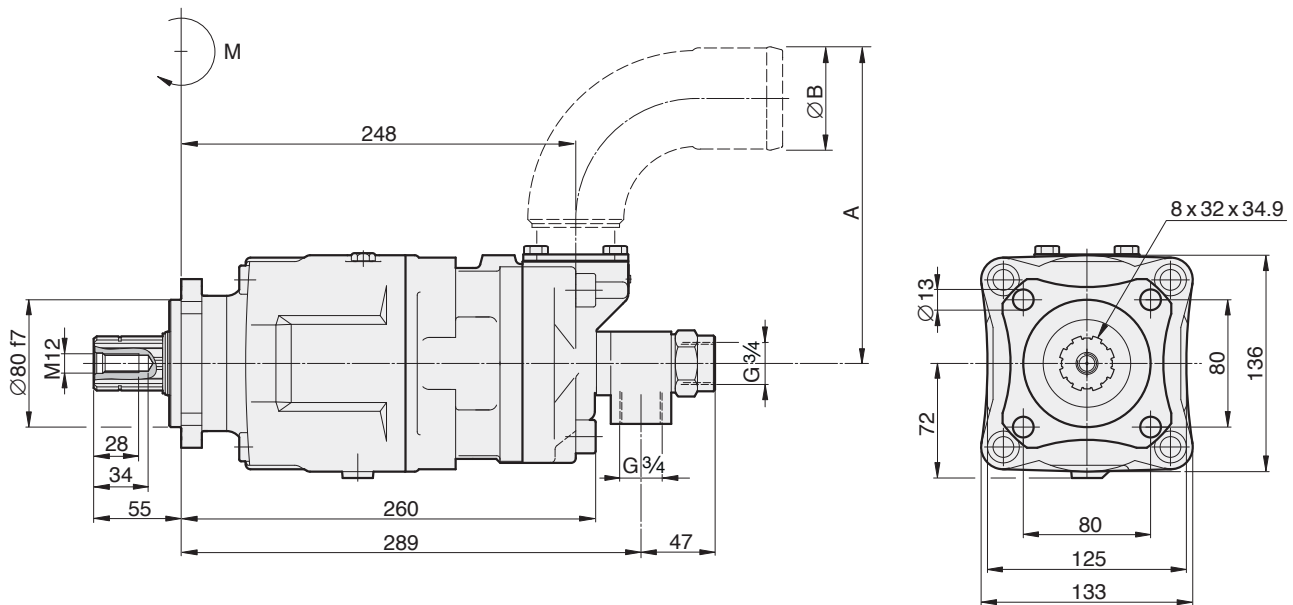

20/20, 28/28, 35/35, 46/46, 53/53

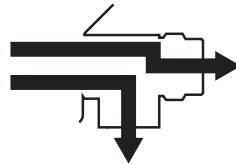

40/20, 56/28, 64/32

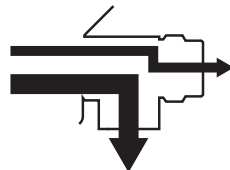

Spline shaft:
DIN 5462 / ISO 14
Mounting flange:
ISO 7653-D