

Axial piston variable motor A10VM

Axial piston plug-in motor A10VE

series 52

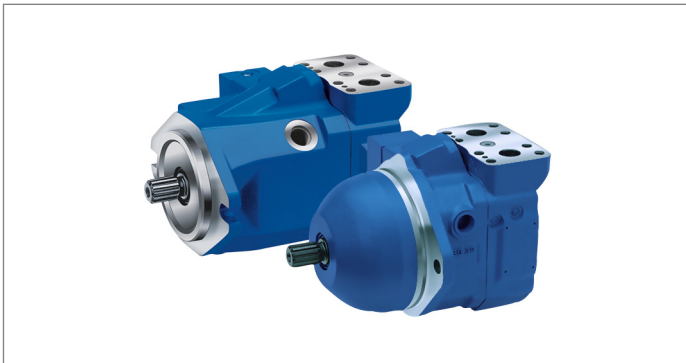

- ▶ Medium pressure motor with two-point control
- ▶ Sizes 28 to 85
- ▶ Nominal pressure 280 bar
- ▶ Maximum pressure 350 bar
- ▶ Open and closed circuit

Features

- ▶ Variable displacement motor with well-trying A10-rotary unit technology
- ▶ Approved for high rotational speeds
- ▶ Long service life
- ▶ High power density
- ▶ Low noise
- ▶ Minimum swivel angle can be adjusted externally
- ▶ Swashplate design

Inhalt

| | |
|--|----|
| Type code A10VM | 2 |
| Type code A10VE | 4 |
| Hydraulic fluids | 6 |
| Working pressure range | 8 |
| Technical data | 9 |
| DG – Two-point control, direct operated | 11 |
| HZ/HZ6 – Two-point control, hydraulic | 12 |
| EZ1, EZ2, EZ6, EZ7 – Two-point control, electric | 13 |
| A10VM – Dimensions, size 28 to 85 | 14 |
| A10VE – Dimensions, size 28 to 63 | 26 |
| Flushing and boost-pressure valve | 35 |
| Speed sensing | 36 |
| Pin assignment, speed sensor DSA1 and DSA2 | |
| Order option C and K | 36 |
| Dimension A10VE with speed sensor DSAX and DST | 37 |
| Connector for solenoids | 37 |
| Installation instructions for A10VM | 38 |
| Installation instructions for A10VE | 40 |
| Project planning notes | 42 |
| Safety instructions | 43 |

Type code A10VM

| | | | | | | | | | | | | | |
|-------------|----------|----|----|----------|----|----------|----|----------|----------|----|----------|----|----|
| 01 | 02 | 03 | 04 | 05 | 06 | 07 | 08 | 09 | 10 | 11 | 12 | 13 | 14 |
| A10V | M | | | / | | W | | - | V | | C | | |

Axial piston unit

| | | |
|----|---|-------------|
| 01 | Swashplate design, variable, nominal pressure 280 bar, maximum pressure 350 bar | A10V |
|----|---|-------------|

Operating mode

| | | |
|----|--------------------------------|----------|
| 02 | Motor, open and closed circuit | M |
|----|--------------------------------|----------|

Size (NG)

| | | | | | |
|----|---|-----------|-----------|-----------|-----------|
| 03 | For geometric displacement, see table of values, page 9 | 28 | 45 | 63 | 85 |
|----|---|-----------|-----------|-----------|-----------|

Control devices

| | | 28 | 45 | 63 | 85 | |
|----|--|-------------------|------------------------|---------|------------|------------|
| 04 | Two-point control direct operated, external control pressure supply without on/off valve | hydraulic | switching time orifice | without | with | DG |
| | | | | without | with | HZ |
| | electric with switching solenoid | $U = 12\text{ V}$ | switching time orifice | without | with | HZ6 |
| | | | | without | with | EZ1 |
| | | $U = 24\text{ V}$ | switching time orifice | without | with | EZ6 |
| | | | | without | with | EZ2 |
| | | | | | EZ7 | |

Series 28 ... 85

| | | | |
|----|-------------------|---|-----------|
| 05 | Series 5, index 2 | • | 52 |
|----|-------------------|---|-----------|

Direction of rotation 28 ... 85

| | | | | |
|----|-----------------------|----------|---|----------|
| 06 | Viewed on drive shaft | Variable | • | W |
|----|-----------------------|----------|---|----------|

Minimum displacement 28 45 63 85

| | | | | | | | |
|----|---|---------|------|-------|-------|-------|----------|
| 07 | $V_{g\ min}$ [cm ³] steplessly adjustable ¹⁾ | from/to | 8/28 | 12/25 | 16/38 | 22/50 | 1 |
| | | from/to | - | 26/45 | 40/62 | 48/85 | 2 |

Sealing material 28 ... 85

| | | | |
|----|-----------------------|---|----------|
| 08 | FKM (fluoroelastomer) | • | V |
|----|-----------------------|---|----------|

Drive shaft

| | | | | | | | |
|----|-------------------------------------|--------------------|---|---|---|---|----------|
| 09 | Splined shaft similar to ISO 3019-1 | for high torque | • | • | • | • | R |
| | | for reduced torque | - | • | • | • | W |

Mounting flange 28 ... 85

| | | | |
|----|-----------------------------------|---|----------|
| 10 | Based on ISO 3019-1 (SAE); 2 hole | • | C |
|----|-----------------------------------|---|----------|

• = Available ◦ = On request - = Not available

1) Please specify exact setting value in plain text.

| | | | | | | | | | | | | | |
|-------------|----------|----|----|----------|----|----------|----|----------|----------|----|----------|----|----|
| 01 | 02 | 03 | 04 | 05 | 06 | 07 | 08 | 09 | 10 | 11 | 12 | 13 | 14 |
| A10V | M | | | / | | W | | - | V | | C | | |

| Working port | | | 28 | 45 | 63 | 85 | |
|---------------------|---------------------------------------|--|-----------|-----------|-----------|-----------|--------------|
| 11 | Flange ports according to ISO 6162 | A and B laterally, Metric fastening thread same side, | ● | ● | ● | ● | 10N00 |
| | | A and B ; at rear; Metric fastening thread | - | ● | - | - | 11N00 |
| | Threaded port according to DIN 3852-1 | A and B laterally, Threaded port, metric same side, | ● | ● | ● | - | 16N00 |
| | Flange ports according to ISO 6162 | A and B laterally, Fastening thread UNF same side, | ● | ● | ● | ● | 60N00 |
| | | A and B ; at rear; Fastening thread UNF | - | ● | - | - | 61N00 |
| | Threaded port according to ISO 11926 | A and B laterally, Threaded port, UN same side, | ● | ● | ● | - | 66N00 |

| Valves | | | 28 | 45 | 63 | 85 | |
|---------------|---|--|-----------|-----------|-----------|-----------|----------|
| 12 | Without valve | | ● | ● | ● | ● | 0 |
| | Integrated flushing valve (only with working line ports 10N00, 60N00 and 16N00, 66N00) | | ● | ● | ● | ● | 7 |

| Speed sensing | | | 28 | 45 | 63 | 85 | |
|----------------------|--|--|-----------|-----------|-----------|-----------|--|
| 13 | Without speed sensing (without symbol) | | ● | ● | ● | ● | |

| Connector for solenoids | | | 28 | 45 | 63 | 85 | |
|--------------------------------|--|--|-----------|-----------|-----------|-----------|----------|
| 14 | Without connector (without solenoid, only for hydraulic control) | | ● | ● | ● | ● | |
| | DEUTSCH - molded connector, 2-pin – without suppressor diode | | ● | ● | ● | ● | P |

● = Available ○ = On request - = Not available

Notice

- ▶ Note the project planning notes on page 42.
- ▶ In addition to the type code, please specify the relevant technical data when placing your order.

1) Type code, technical data, dimensions and information on the connector, plus safety instructions about the sensor can be found in the relevant data sheet 95131 (DST) or 95126 (DSA/20).

Type code A10VE

| | | | | | | | | | | | | | |
|-------------|----------|----|----|----------|-----------|----------|----|----------|----------|----|----------|----|----|
| 01 | 02 | 03 | 04 | 05 | 06 | 07 | 08 | 09 | 10 | 11 | 12 | 13 | 14 |
| A10V | E | | | / | 52 | W | | - | V | | F | | |

Axial piston unit

| | | |
|----|---|-------------|
| 01 | Swashplate design, variable, nominal pressure 280 bar, maximum pressure 350 bar | A10V |
|----|---|-------------|

Operating mode

| | | |
|----|---|----------|
| 02 | Motor, plug-in design, open and closed circuits | E |
|----|---|----------|

Size (NG)

| | | | | |
|----|---|-----------|-----------|-----------|
| 03 | For geometric displacement, see table of values, page 9 | 28 | 45 | 63 |
|----|---|-----------|-----------|-----------|

Control devices

| | | | | 28 | 45 | 63 | |
|----|-------------------|--|------------------------|-----------|-----------|------------|------------|
| 04 | Two-point control | direct operated, external control pressure supply without on/off valve | | ● | ● | ○ | DG |
| | | hydraulic | switching time orifice | without | ● | ● | HZ |
| | | | with | ● | ● | HZ6 | |
| | electric | $U = 12\text{ V}$ | switching time orifice | without | ● | ● | EZ1 |
| | | | with | ● | ● | EZ6 | |
| | | with switching solenoid | | | | | |
| | | $U = 24\text{ V}$ | switching time orifice | without | ● | ● | EZ2 |
| | | | with | ● | ● | EZ7 | |

Series 28 ... 63

| | | | |
|----|-------------------|---|-----------|
| 05 | Series 5, index 2 | ● | 52 |
|----|-------------------|---|-----------|

Direction of rotation 28 ... 63

| | | | | |
|----|-----------------------|----------|---|----------|
| 06 | Viewed on drive shaft | Variable | ● | W |
|----|-----------------------|----------|---|----------|

Minimum displacement 28 45 63

| | | | | | | |
|----|---|---------|-------|-------|-------|----------|
| 07 | $V_{g\text{ min}}$ [cm ³] steplessly adjustable ¹⁾ | from/to | 10/28 | 12/25 | 16/38 | 1 |
| | | from/to | - | 26/45 | 40/62 | 2 |

Sealing material 28 ... 63

| | | | |
|----|-----------------------|---|----------|
| 08 | FKM (fluoroelastomer) | ● | V |
|----|-----------------------|---|----------|

Drive shaft 28 45 63

| | | | | | | |
|----|-------------------------------------|--------------------|---|---|---|----------|
| 09 | Splined shaft similar to ISO 3019-1 | for high torque | ● | ● | ● | R |
| | | for reduced torque | - | ● | ● | W |

Mounting flange 28 ... 63

| | | | |
|----|------------------------|---|----------|
| 10 | Special flange; 2 hole | ● | F |
|----|------------------------|---|----------|

● = Available ○ = On request - = Not available

¹⁾ Please specify exact setting value in plain text.

| | | | | | | | | | | | | | |
|-------------|----------|----|----|----------|-----------|----------|----------|----------|----|----------|----|----|----|
| 01 | 02 | 03 | 04 | 05 | 06 | 07 | 08 | 09 | 10 | 11 | 12 | 13 | 14 |
| A10V | E | | | / | 52 | W | - | V | | F | | | |

| Working port | | | | 28 | 45 | 63 | |
|---------------------|---------------------------------------|-------------------------------|-------------------------|----|----|----|--------------|
| 11 | Flange ports according to ISO 6162 | A and B laterally, same side, | Metric fastening thread | ● | ● | ● | 10N00 |
| | | A and B; at rear; | Metric fastening thread | - | ● | - | 11N00 |
| | Threaded port according to DIN 3852-1 | A and B laterally, same side, | Threaded port, metric | ● | ● | ● | 16N00 |
| | Flange ports according to ISO 6162 | A and B laterally, same side, | Fastening thread UNF | ● | ● | ● | 60N00 |
| | | A and B; at rear; | Fastening thread UNF | - | ● | - | 61N00 |
| | Threaded port according to ISO 11926 | A and B laterally, same side, | Threaded port, UN | ● | ● | ● | 66N00 |

| Valves | | | | 28 | 45 | 63 | |
|---------------|--|--|--|----|----|----|----------|
| 12 | Without valve | | | ● | ● | ● | 0 |
| | Integrated flushing valve (only with working line ports 10N00, 60N00 and 16N00, 66N00) | | | - | ● | ● | 7 |

| Speed sensing | | | | 28 | 45 | 63 | |
|----------------------|---|--|--|----|----|----|-----------------------|
| 13 | Without speed sensing (without symbol) | | | ● | ● | ● | |
| | Prepared for sensor DST or DSAX/20 | | | ○ | ○ | - | W |
| | Sensor DSA1/20 mounted (1 = one frequency and direction of rotation signal) | | | ○ | ○ | - | C¹⁾ |
| | Sensor DSA2/20 mounted (2 = two 90° phase-shifted frequency signals) | | | ○ | ○ | - | K¹⁾ |
| | DST sensor mounted | | | ○ | ○ | - | E¹⁾ |

| Connector for solenoids | | | | 28 | 45 | 63 | |
|--------------------------------|--|--|--|----|----|----|----------|
| 14 | Without connector (without solenoid, only for hydraulic control) | | | ● | ● | ● | |
| | DEUTSCH - molded connector, 2-pin - without suppressor diode | | | ● | ● | ● | P |

● = Available ○ = On request - = Not available

Notice

- ▶ Note the project planning notes on page 42.
- ▶ In addition to the type code, please specify the relevant technical data when placing your order.

1) Type code, technical data, dimensions and information on the connector, plus safety instructions about the sensor can be found in the relevant data sheet 95131 (DST) or 95126 (DSAX/20).

Hydraulic fluids

The variable displacement motor A10VM/A10VE is designed for operation with HLP mineral oil according to DIN 51524.

Application instructions and requirements for hydraulic fluid selection, behavior during operation as well as disposal and environmental protection should be taken from the following data sheets before the start of project planning:

- ▶ 90220: Hydraulic fluids based on mineral oils and related hydrocarbons
- ▶ 90221: Environmentally acceptable hydraulic fluids

Selection of hydraulic fluid

Bosch Rexroth evaluates hydraulic fluids on the basis of the Fluid Rating according to the technical data sheet 90235.

Hydraulic fluids with positive evaluation in the Fluid Rating are listed in the following data sheet:

- ▶ 90245: Bosch Rexroth Fluid Rating List for Rexroth hydraulic components (pumps and motors)

The hydraulic fluid should be selected so that the operating viscosity in the operating temperature range is within the optimum range (v_{opt} ; see selection diagram).

Viscosity and temperature of hydraulic fluids

| | Viscosity | Shaft seal | Temperature ²⁾ | Remarks |
|-----------------------------|--|------------|---|---|
| Cold start | $v_{max} \leq 1600 \text{ mm}^2/\text{s}$ | FKM | $\vartheta_{St} \geq -25^\circ\text{C}$ | $t \leq 3 \text{ min}$, without load ($p \leq 30 \text{ bar}$), $n \leq 1000 \text{ rpm}$ Permissible temperature difference between axial piston unit and hydraulic fluid in the system maximum 25 K |
| Warm-up phase | $v = 1600 \dots 400 \text{ mm}^2/\text{s}$ | | | $t \leq 15 \text{ min}$, $p \leq 0.7 \times p_{nom}$ and $n \leq 0.5 \times n_{nom}$ |
| Permissible operating range | $v = 400 \dots 10 \text{ mm}^2/\text{s}$ ¹⁾ | FKM | $\vartheta \leq +110^\circ\text{C}$ | Measured at port L_x |
| | $v_{opt} = 36 \dots 16 \text{ mm}^2/\text{s}$ | | | Optimal operating viscosity and efficiency range |
| Short-term operation | $v_{min} = 10 \dots 7 \text{ mm}^2/\text{s}$ | FKM | $\vartheta \leq +110^\circ\text{C}$ | $t \leq 1 \text{ min}$, $p \leq 0.3 \times p_{nom}$, measured at port L_x |

▼ Selection diagram

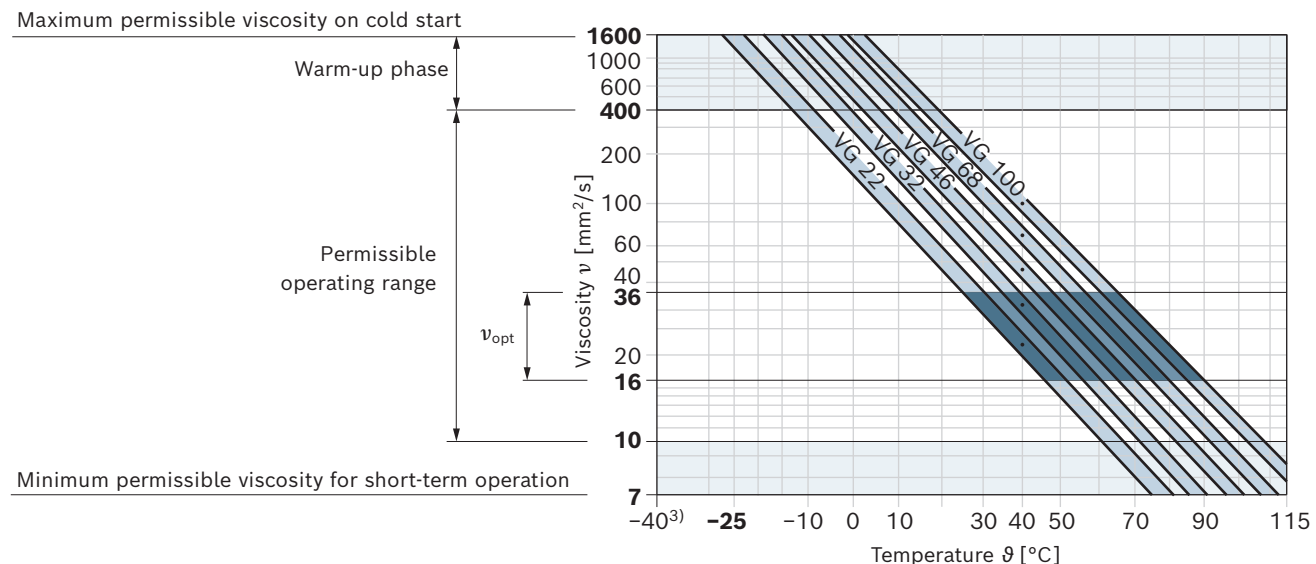

1) This corresponds, for example on the VG 46, to a temperature range of +4°C to +85°C (see selection diagram)

2) If the temperature at extreme operating parameters cannot be adhered to, please contact us.

3) For applications in the low-temperature range, please contact us.

Filtration of the hydraulic fluid

Finer filtration improves the cleanliness level of the hydraulic fluid, which increases the service life of the axial piston unit.

A cleanliness level of at least 20/18/15 under ISO 4406 should be maintained.

At a hydraulic fluid viscosity of less than 10 mm²/s (e.g. due to high temperatures during short-term operation) at the drain port, a cleanliness level of at least 19/17/14 under ISO 4406 is required.

Examples of temperatures of hydraulic fluids at a viscosity of 10 mm²/s:

- ▶ 73 °C at HLP 32
- ▶ 85 °C at HLP 46

Working pressure range

| Pressure at working port A or B | | Definition |
|--|----------------|--|
| Nominal pressure p_{nom} | 280 bar | The nominal pressure corresponds to the maximum design pressure. |
| Maximum pressure p_{max} | 350 bar | The maximum pressure corresponds to the maximum working pressure within a single operating period. The sum of single operating periods must not exceed the total operating period. |
| Single operating period | 2.5 ms | |
| Total operating period | 300 h | |
| Minimum pressure $p_{HD absolute}$ (high-pressure side) | 10 bar | Minimum pressure on the high-pressure side (A or B) required to prevent damage to the axial piston unit. |
| Rate of pressure change $R_{A max}$ | 16000 bar/s | Maximum permissible speed of pressure build-up and reduction during a pressure change across the entire pressure range. |
| Pressure at port A or B (low-pressure side) | | |
| Minimum pressure $p_{ND min}$ | 2 bar absolute | Minimum pressure on the low-pressure side (A or B) required to prevent damage to the axial piston unit (see diagram, page 9). |
| Leakage pressure at port L, L ₁ | | |
| Max. static pressure $p_{L max}$ | 2 bar absolute | Maximum 0.5 bar higher than inlet pressure at port A or B , but not higher than $p_{L max}$. A drain line to the reservoir is required. |

▼ Pressure definition

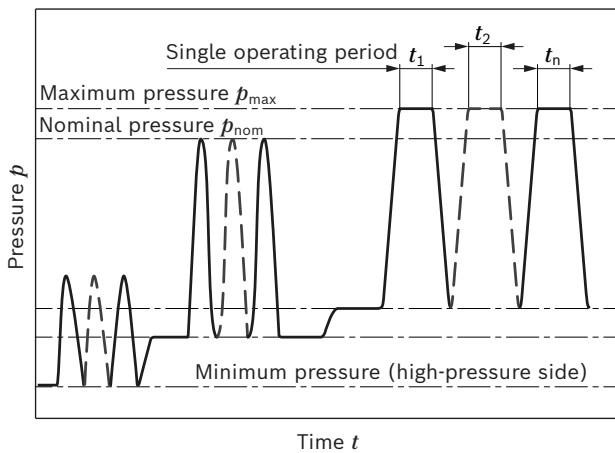

Total operating period = $t_1 + t_2 + \dots + t_n$

▼ Rate of pressure change $R_{A max}$

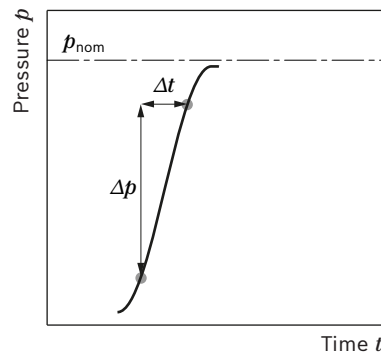

Flow direction

| Direction of rotation viewed on drive shaft | clockwise | Counter-clockwise |
|--|---------------|-------------------|
| | B to A | A to B |

Notice

Working pressure range applies when using hydraulic fluids based on mineral oils. Please contact us for values for other hydraulic fluids.

Technical data

| Size | | NG | 28 | 45 | 63 | 85 | |
|---|--------------------------------------|-----------------------|--------------------|-------------------|--------|--------|--------|
| Displacement geometric, per revolution | | $V_{g \max}$ | cm ³ | 28 | 45 | 62 | 87 |
| | | $V_{g \min}^*$ | cm ³ | 8 (VM) 10 (VE) | 12 | 16 | 22 |
| Maximum rotational speed ¹⁾²⁾ | at $V_{g \max}$ | n_{nom} | rpm | 4700 | 4000 | 3300 | 3100 |
| | at $V_{g \min}$ | $n_{\text{max perm}}$ | rpm | 5400 | 4600 | 3900 | 3560 |
| Minimum rotational speed continuous operation | at $V_{g \max}$ | n_{min} | rpm | 250 | 250 | 250 | 250 |
| Inlet flow | at n_{nom} and $V_{g \max}$ | $q_{v \max}$ | l/min | 131.6 | 180 | 205 | 270 |
| Torque | at $V_{g \max}$ and $p_N = 280$ bar | M_{max} | Nm | 125 | 200 | 276 | 387 |
| Actual starting torque, approx. | at $n = 0$ rpm and $p_N = 280$ bar | M | Nm | 92 | 149 | 205 | 253 |
| Rotary stiffness of drive shaft | R | c | Nm/rad | 2600 | 41000 | 69400 | 152900 |
| | W | c | Nm/rad | 19800 | 34400 | 54000 | 117900 |
| Moment of inertia of the rotary group | | J_{TW} | kgm ² | 0.0017 | 0.0033 | 0.0056 | 0,012 |
| Maximum angular acceleration ³⁾ | | α | rad/s ² | 5500 | 4000 | 3300 | 2700 |
| Case volume | | V | l | 0.6 | 0.7 | 0.8 | 1.0 |
| Weight approx. | | m | kg | 14 | 18 | 26 | 34 |

Permissible motor speed depending on output pressure (low pressure)

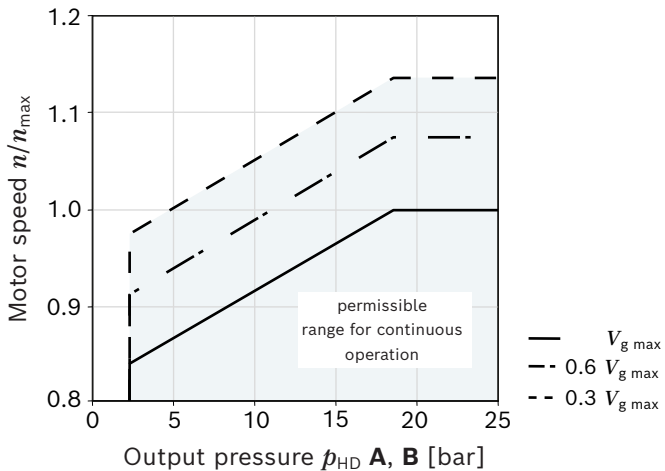

Notice

- ▶ Theoretical values, without efficiency and tolerances; values rounded
- ▶ Operation above the maximum values or below the minimum values may result in a loss of function, a reduced service life or in the destruction of the axial piston unit. Bosch Rexroth recommends checking loads through tests or calculation/simulation and comparing them with the permissible values.
- ▶ **Setting of minimum displacement*):** The minimum displacement can be steplessly adjusted within the ranges (or screw length) of type code position 1 or 2. Please specify minimum displacement in plain text.

For formulas to determine the characteristics, see page 10

- The values are applicable:
 - for the optimum viscosity range from $\nu_{\text{opt}} = 36$ to $16 \text{ mm}^2/\text{s}$
 - with hydraulic fluid based on mineral oils
- The maximum rotational speed depends on the output pressure at the working port **A (B)** (see diagram).

- The data are valid for values between the minimum required and maximum permissible rotational speed. Valid for external excitation (e.g. diesel engine 2 to 8 times rotary frequency; cardan shaft twice the rotary frequency). The limit value is only valid for a single pump. The load capacity of the connection parts must be considered.

| Determination of the characteristics | | |
|--------------------------------------|---|---------|
| Flow | $q_v = \frac{V_g \times n}{1000 \times \eta_v}$ | [l/min] |
| Torque | $M = \frac{1.59 \times V_g \times \Delta p \times \eta_{hm}}{100}$ | [Nm] |
| Power | $P = \frac{2 \pi \times M \times n}{60000} = \frac{q_v \times \Delta p \times \eta_t}{600}$ | [kW] |
| Output speed | $n = \frac{q_v \times 1000 \times \eta_v}{V_g}$ | [rpm] |

Key

- V_g = Displacement per revolution [cm³]
- Δp = Differential pressure [bar]
- n = Rotational speed [rpm]
- η_v = Volumetric efficiency
- η_{hm} = Hydraulic-mechanical efficiency
- η_t = Total efficiency ($\eta_t = \eta_v \times \eta_{hm}$)

Permissible radial and axial loading on the drive shafts

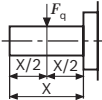
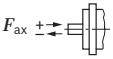
| Size | | NG | 28 | 45 | 63 | 85 |
|-----------------------------|---|---------------------|------|------|------|------|
| Maximum radial force at X/2 |  | $F_{q \max}$ N | 1200 | 1500 | 1700 | 2000 |
| Maximum axial force |  | $\pm F_{ax \max}$ N | 1000 | 1500 | 2000 | 3000 |

Notice

- The specified values are maximum values and must not be exceeded in continuous operation. For radial and axial loading, please contact us.

DG – Two-point control, direct operated

The variable displacement motor is set to minimum swivel angle by connecting an external switching pressure to port **G** (**G₁**).

This will supply control fluid directly to the stroking piston; a minimum control pressure of $p_{st} \geq 40$ bar is required.

The variable displacement motor can only be switched between $V_{g \max}$ or $V_{g \min}$. $V_{g \min}$ Please specify the pre-setting in plain text.

Please note that the required switching pressure at port **G** (**G₁**) is directly dependent on the actual working pressure p_B in port **A** or **B**. (See switching pressure characteristic curve).

The maximum permissible switching pressure is 280 bar.

- ▶ Switching pressure p_{st} in **G** (**G₁**) = 0 bar $\triangleq V_{g \max}$
- ▶ Switching pressure p_{st} in **G** (**G₁**) ≥ 40 bar $\triangleq V_{g \min}$

▼ Switching pressure characteristic curve

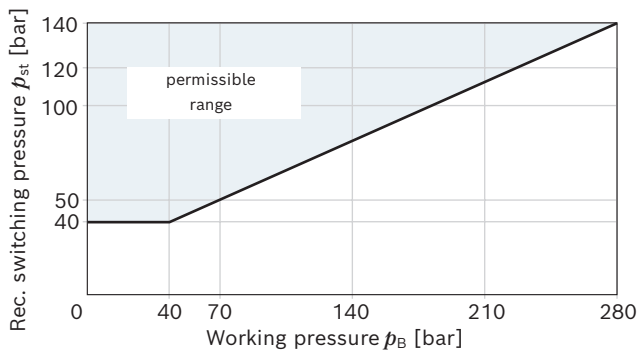

▼ Circuit diagram

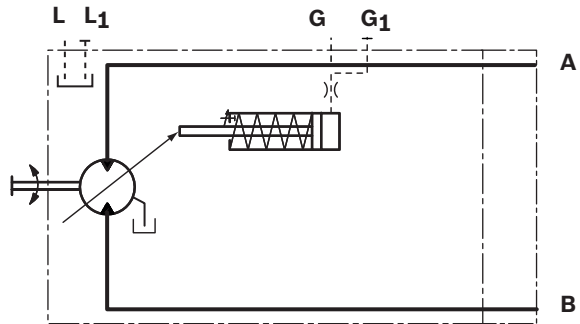

HZ/HZ6 – Two-point control, hydraulic

The variable motor is set to minimum swivel angle by connecting the pilot pressure p_X to port **X** ($p_X \geq 30$ bar). This supplies the stroking piston with control pressure via the on/off valve.

The control pressure is taken internally from the relevant high-pressure side; a minimum working pressure difference of $\Delta p_{A,B} \geq 30$ bar is required.

The motor can only be switched between $V_{g \max}$ oder $V_{g \min}$.
 $V_{g \min}$ - pre-setting for order please state in plain text.

Pilot pressure $p_X \leq 10$ bar $\triangleq V_{g \max}$

Pilot pressure $p_X \geq 30$ bar $\triangleq V_{g \min}$

▼ HZ/HZ6 characteristic curve

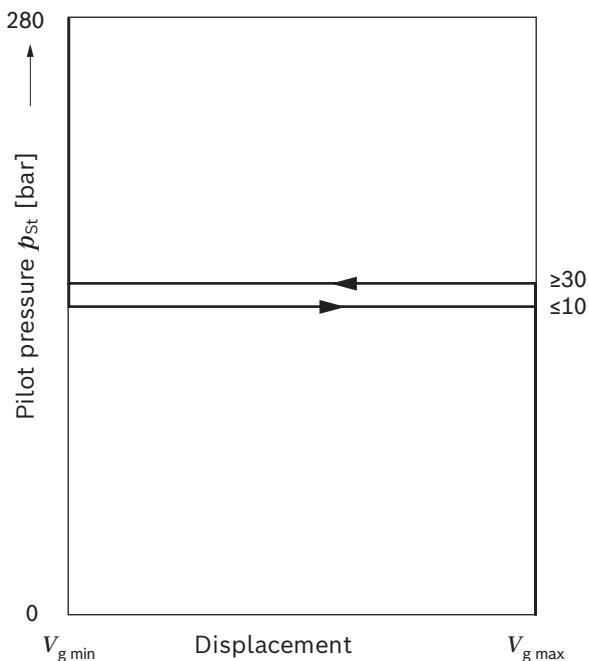

HZ/HZ6 characteristics

| | |
|------------------------------------|---------|
| Minimum pilot pressure | 30 bar |
| Maximum permissible pilot pressure | 280 bar |

Version HZ6 with orifice for the switching time extension

The switching process is delayed by an orifice.

This allows for damped switching.

Standard orifice diameter is 0.25 mm.

Other orifice diameters upon request.

▼ HZ circuit diagram

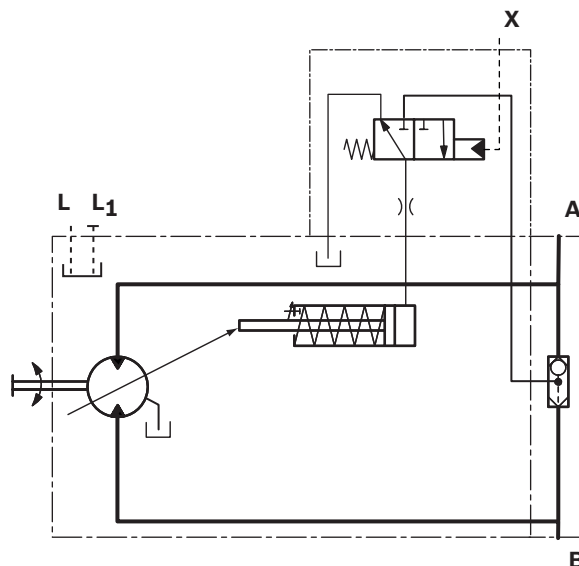

▼ HZ6 circuit diagram

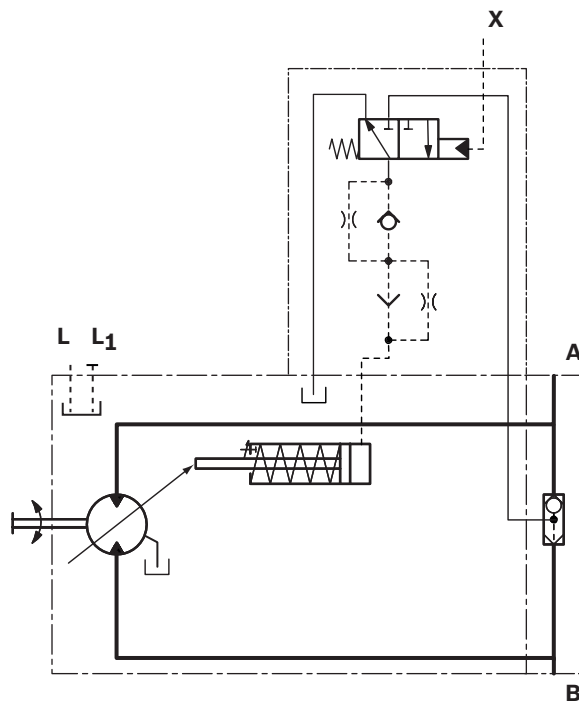

EZ1, EZ2, EZ6, EZ7 – Two-point control, electric

The variable displacement motor is set to minimum swivel angle by actuating the switching solenoid. This supplies the stroking piston with control pressure via the on/off valve.

The control pressure is taken internally from the relevant high-pressure side; a minimum working pressure difference of $\Delta p_{A,B} \geq 30 \text{ bar}$ is required.

The motor can only be switched between $V_{g \text{ max}}$ oder $V_{g \text{ min}}$. $V_{g \text{ min}}$ - pre-setting for order please state in plain text.

▼ EZx characteristic curve

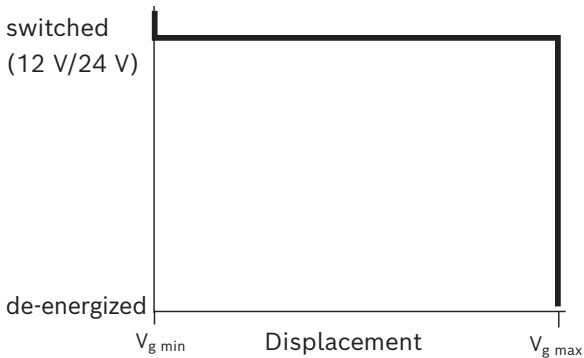

De-energized $\triangleq V_{g \text{ max}}$
 Energized $\triangleq V_{g \text{ min}}$

| Solenoid technical data | EZ1/EZ6 | EZ2/EZ7 |
|---|--|-------------------|
| Nominal voltage | 12V DC $\pm 15\%$ | 24V DC $\pm 15\%$ |
| Nominal current at 20 °C | 1.5 A | 0.8 A |
| Duty cycle | 100% | 100% |
| Type of protection of device connector | see connector for solenoids on page 37 | |
| Ambient temperature | -20 °C to +60 °C | |
| Hydraulic fluid temperature | -20 °C to +100 °C | |
| Viscosity range in continuous operation | 10 mm ² /s to 420mm ² /s ¹⁾ | |

Please contact us if the temperature and viscosity ranges cannot be complied with.

EZ6/EZ7 version with orifice for switching time extension

The switching process is delayed by an orifice. This allows for damped switching. Standard orifice diameter is 0.25 mm. Other orifice diameters upon request.

▼ EZ1/EZ2 circuit diagram

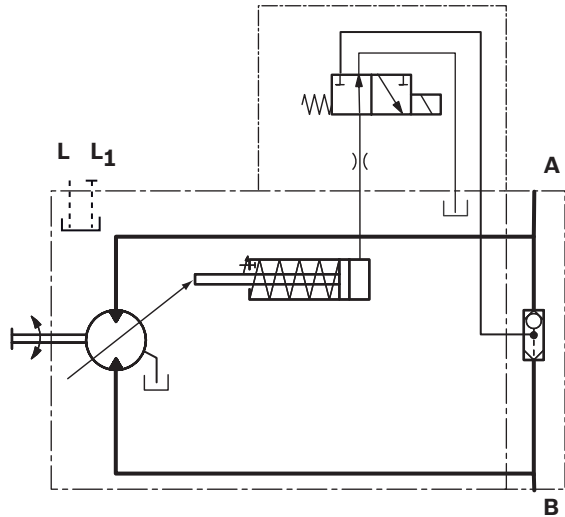

▼ EZ6/EZ7 circuit diagram

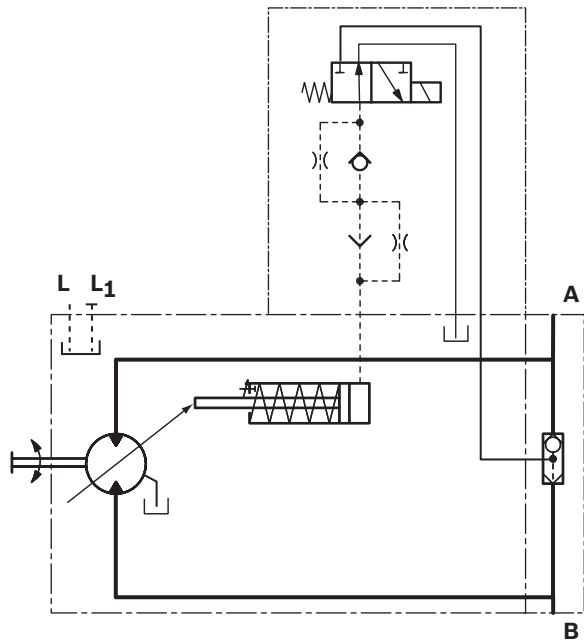

1) In the range between 420 mm²/s and 1600 mm²/s only limited function

A10VM – Dimensions, size 28

DG – Two-point control, direct operated

Port plate 10 (60) and 16 (66) N000

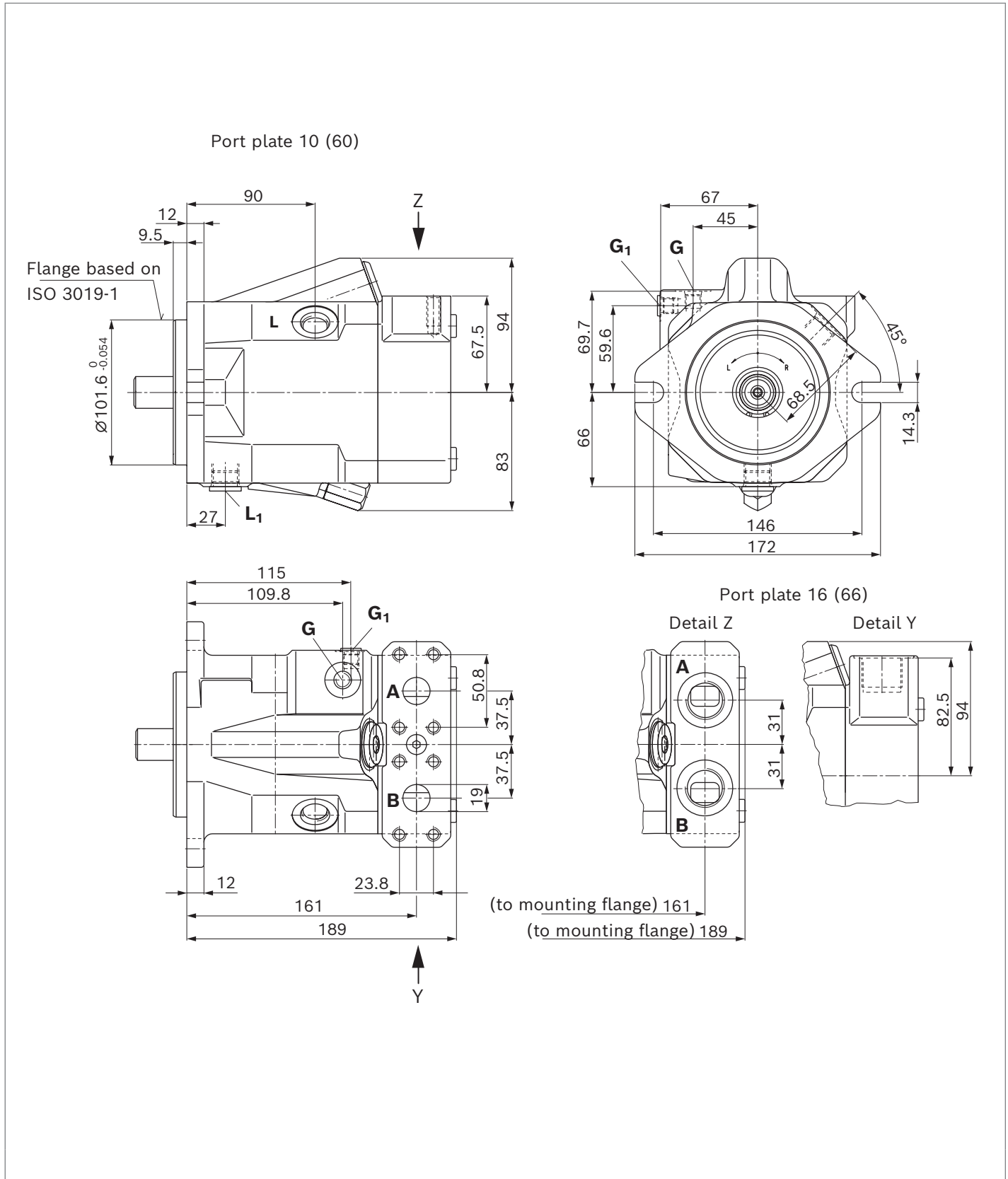

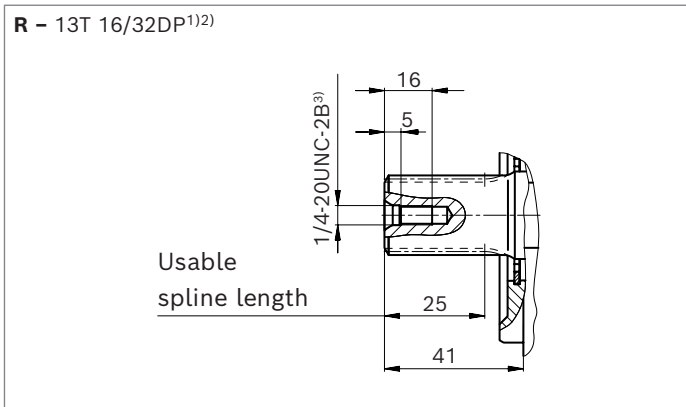
▼ **Splined shaft 7/8 in (similar to ISO 3019-1)**

| Port plate ports | | Standard | Size | p_{\max} [bar] ⁴⁾ | State ⁷⁾ |
|----------------------|---|-------------------------|---------------------------------|--------------------------------|---------------------|
| Port plate 10 | | | | | |
| A, B | Working port (high-pressure series) Fastening thread | ISO 6162-2 DIN 13 | 3/4 in M10 × 1.5; 17 deep | 350 | O |
| Port plate 60 | | | | | |
| A, B | Working port (high-pressure series) Fastening thread | ISO 6162-2 ASME B1.1 | 3/4 in 3/8-16UNC-2B; 21 deep | 350 | O |
| Port plate 16 | | | | | |
| A, B | Working port | DIN 3852-1 | M27 × 2; 16 deep | 350 | O |
| Port plate 66 | | | | | |
| A, B | Working port | ISO 11926 | 1 1/16-12UN-2B; 20 deep | 350 | O |
| Other ports | | | | | |
| L | Drain port | ISO 11926 ⁵⁾ | 3/4-16UNF-2B; 15 deep | 4 | O ⁶⁾ |
| L₁ | Drain port | ISO 11926 ⁵⁾ | 3/4-16UNF-2B; 15 deep | 4 | X ⁶⁾ |
| G | External control pressure (with DG control) | ISO 11926 ⁵⁾ | 7/16-20UNF-2B; 12 deep | 350 | O |
| G₁ | External control pressure (with DG control) | ISO 11926 ⁵⁾ | 7/16-20UNF-2B; 12 deep | 350 | X |
| X | Pilot pressure (with HZ control) | ISO 11926 | 7/16-20UNF-2B; 12 deep | 350 | O |

1) Involute spline according to ANSI B92.1a, 30° pressure angle, flat root, side fit, tolerance class 5

2) Spline runout is a deviation from the ISO 3019-1 standard.

3) Thread according to ASME B1.1

4) Depending on the application, momentary pressure peaks can occur. Keep this in mind when selecting measuring devices and fittings.

5) The countersink may be deeper than specified in the standard.

6) Depending on the installation position, **L** or **L₁** must be connected (see also installation instructions on pages 38 and 39).

7) O = Must be connected (plugged on delivery)

X = Plugged (in normal operation)

▼ **HZ, HZ6** – Two-point control, hydraulic

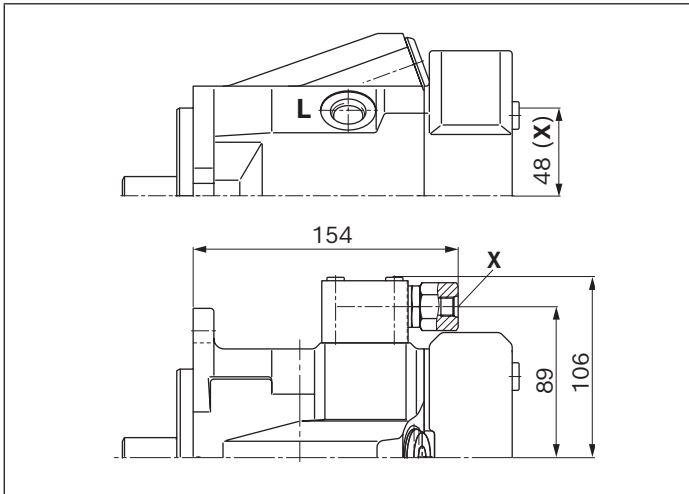

▼ **EZx** – Two-point control, electric

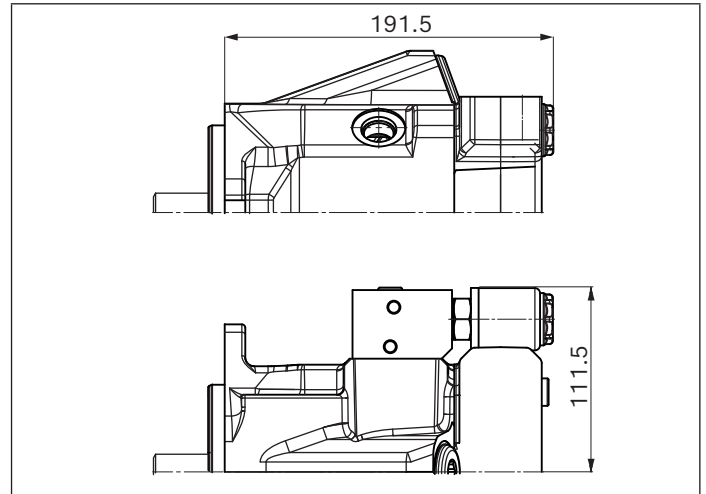

A10VM – Dimensions, size 45

DG – Two-point control, direct operated

Port plate 10 (60), 16 (66) and 11 (61) N000

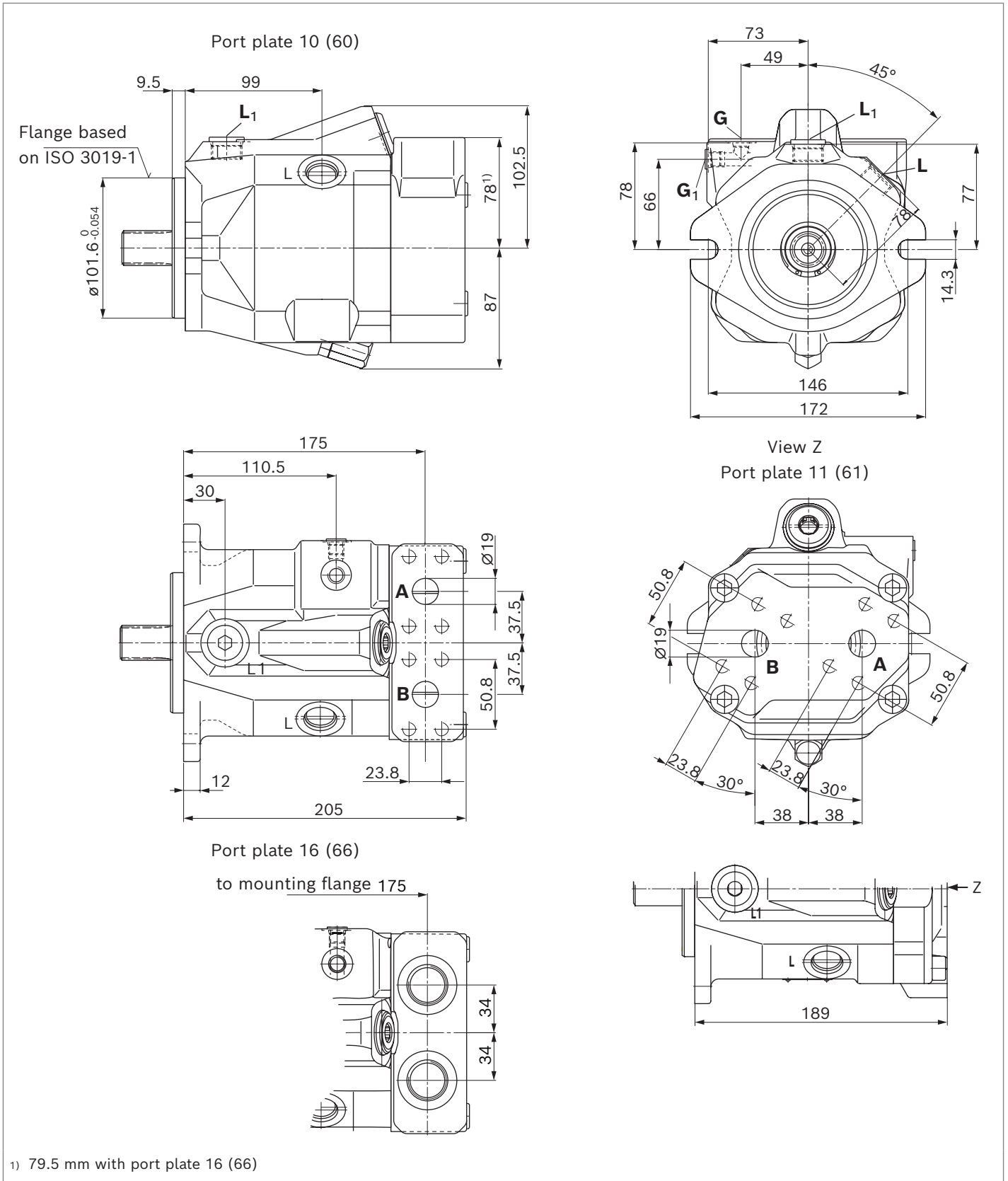

▼ **Splined shaft (similar to ISO 3019-1)**

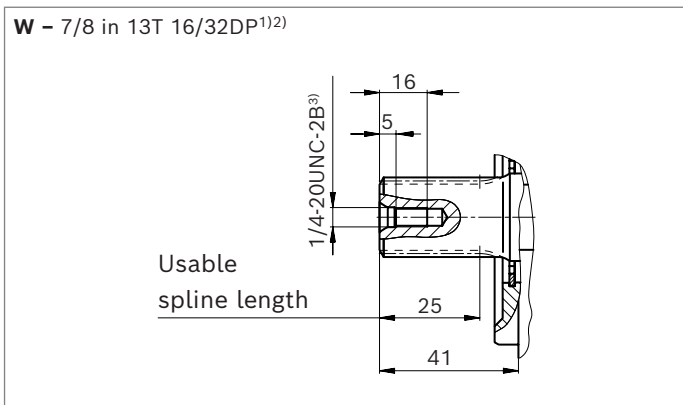
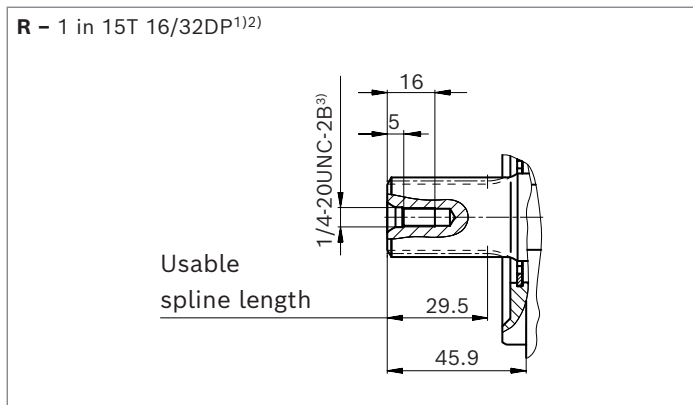

| Port plate ports | | Standard | Size | p_{max} [bar] ⁴⁾ | State ⁷⁾ |
|--------------------------|---|-------------------------|---------------------------------|-------------------------------|---------------------|
| Port plate 10; 11 | | | | | |
| A, B | Working port (high-pressure series) Fastening thread | ISO 6162-2 DIN 13 | 3/4 in M10 × 1.5; 17 deep | 350 | O |
| Port plate 60; 61 | | | | | |
| A, B | Working port (high-pressure series) Fastening thread | ISO 6162-2 ASME B1.1 | 3/4 in 3/8-16UNC-2B; 21 deep | 350 | O |
| Port plate 16 | | | | | |
| A, B | Working port | DIN 3852-1 | M27 × 2; 16 deep | 350 | O |
| Port plate 66 | | | | | |
| A, B | Working port | ISO 11026 | 1 1/16-12UN-2B; 20 deep | 350 | O |
| Other ports | | | | | |
| L | Drain port | ISO 11926 ⁵⁾ | 7/8-14UNF-2B; 17 deep | 4 | O ⁶⁾ |
| L₁ | Drain port | ISO 11926 ⁵⁾ | 7/8-14UNF-2B; 17 deep | 4 | X ⁶⁾ |
| G | External control pressure (with DG control) | ISO 11926 ⁵⁾ | 7/16-20UNF-2B; 12 deep | 350 | O |
| G₁ | External control pressure (with DG control) | ISO 11926 ⁵⁾ | 7/16-20UNF-2B; 12 deep | 350 | X |
| X | Pilot pressure (with HZ control) | ISO 11926 | 7/16-20UNF-2B; 12 deep | 350 | O |

1) Involute spline according to ANSI B92.1a, 30° pressure angle, flat root, side fit, tolerance class 5
 2) Spline runout is a deviation from the ISO 3019-1 standard.
 3) Thread according to ASME B1.1
 4) Depending on the application, momentary pressure peaks can occur. Keep this in mind when selecting measuring devices and fittings.

5) The countersink may be deeper than specified in the standard.
 6) Depending on the installation position, **L** or **L₁** must be connected (see also installation instructions on pages 38 and 39).
 7) O = Must be connected (plugged on delivery)
 X = Plugged (in normal operation)

▼ **HZ, HZ6** – Two-point control, hydraulic

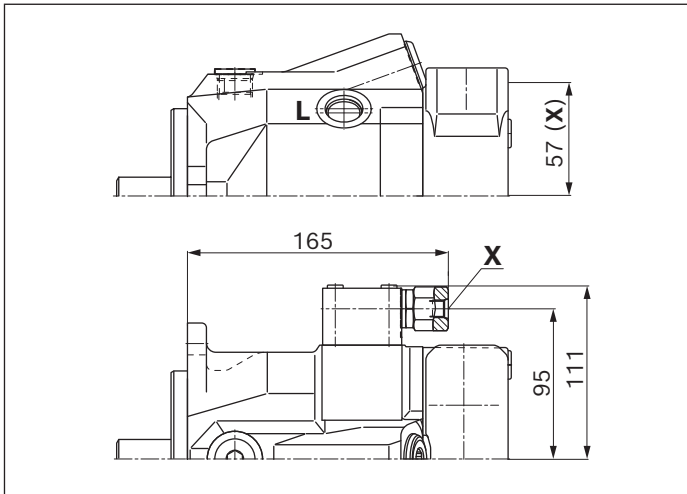

▼ **EZx** – two-point control, electric, port plate 16 (66)

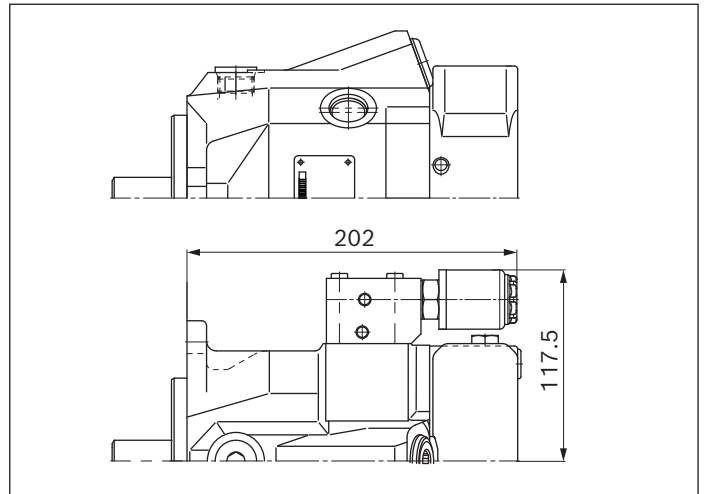

A10VM – Dimensions, size 63

DG – Two-point control, direct operated

Port plate 10 (60) and 16 (66)N000

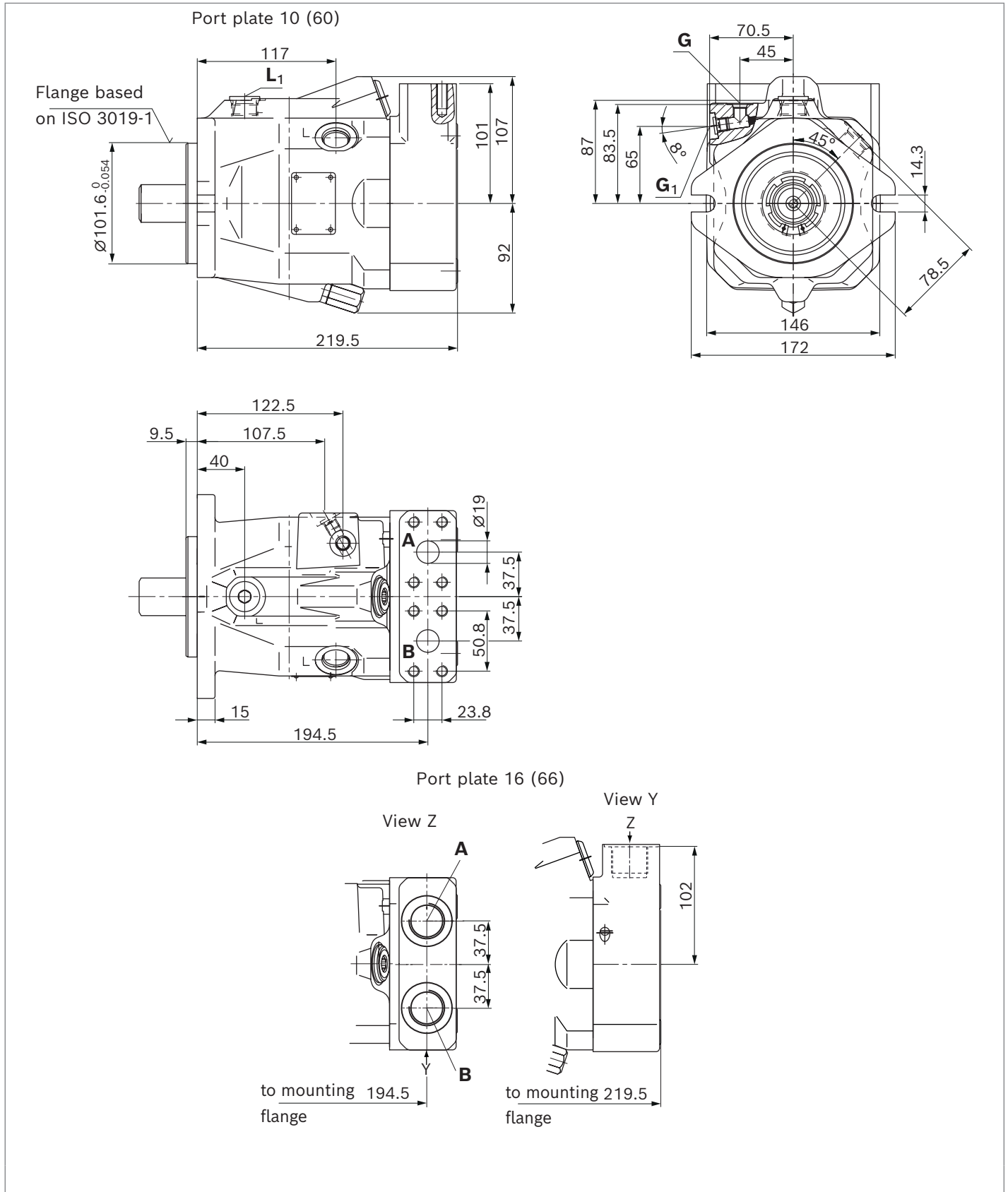

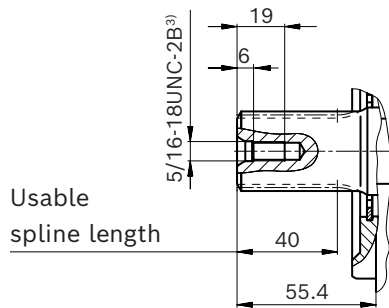
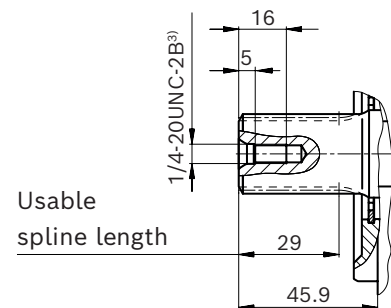
▼ **Splined shaft (similar to ISO 3019-1)****R** – 1 1/4 in 14T 12/24DP¹⁾²⁾**W** – 1 in 15T 16/32DP¹⁾²⁾

| Port plate ports | | Standard | Size | p_{\max} [bar] ⁴⁾ | State ⁷⁾ |
|----------------------|---|-------------------------|---------------------------------|--------------------------------|---------------------|
| Port plate 10 | | | | | |
| A, B | Working port (high-pressure series) Fastening thread | ISO 6162-2 DIN 13 | 3/4 in M10 × 1.5; 17 deep | 350 | O |
| Port plate 60 | | | | | |
| A, B | Working port (high-pressure series) Fastening thread | ISO 6162-2 ASME B1.1 | 3/4 in 3/8-16UNC-2B; 21 deep | 350 | O |
| Port plate 16 | | | | | |
| A, B | Working port | DIN 3852-1 | M27 × 2; 16 deep | 350 | O |
| Port plate 66 | | | | | |
| A, B | Working port | ISO 11926 | 1 1/16-12UN-2B; 20 deep | 350 | O |
| Other ports | | | | | |
| L | Drain port | ISO 11926 ⁵⁾ | 7/8-14UNF-2B; 17 deep | 4 | O ⁶⁾ |
| L₁ | Drain port | ISO 11926 ⁵⁾ | 7/8-14UNF-2B; 17 deep | 4 | X ⁶⁾ |
| G | External control pressure (with DG control) | ISO 11926 ⁵⁾ | 7/16-20UNF-2B; 12 deep | 350 | O |
| G₁ | External control pressure (with DG control) | ISO 11926 ⁵⁾ | 7/16-20UNF-2B; 12 deep | 350 | X |
| X | Pilot pressure (with HZ control) | ISO 11926 | 7/16-20UNF-2B; 12 deep | 350 | O |

- 1) Involute spline according to ANSI B92.1a, 30° pressure angle, flat root, side fit, tolerance class 5
- 2) Spline runout is a deviation from the ISO 3019-1 standard.
- 3) Thread according to ASME B1.1
- 4) Depending on the application, momentary pressure peaks can occur. Keep this in mind when selecting measuring devices and fittings.

- 5) The countersink may be deeper than specified in the standard.
- 6) Depending on the installation position, **L** or **L₁** must be connected (see also installation instructions on pages 38 and 39).
- 7) O = Must be connected (plugged on delivery)
X = Plugged (in normal operation)

▼ **HZ, HZ6** – Two-point control, hydraulic

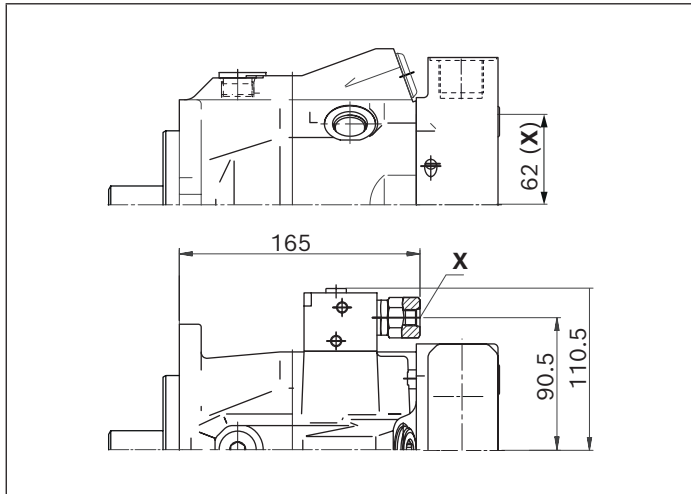

▼ **EZx** – Two-point control, electric

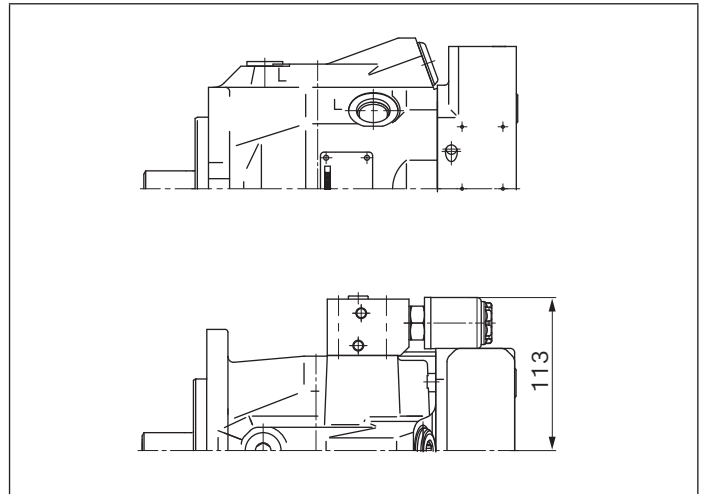

A10VM – Dimensions, size 85

DG – Two-point control, direct operated

Port plate 10, 60 (N000)

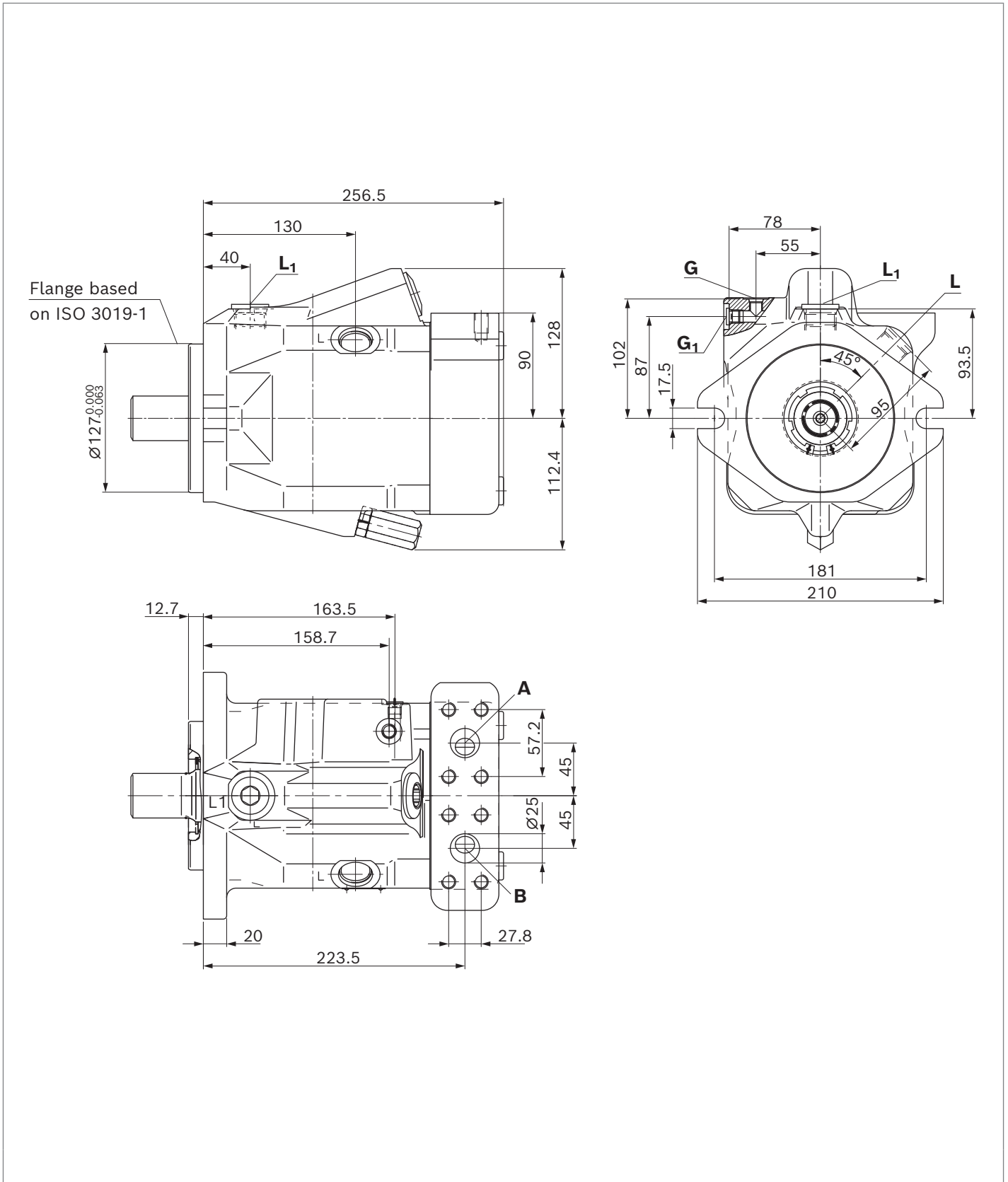

▼ **Splined shaft (similar to ISO 3019-1)**

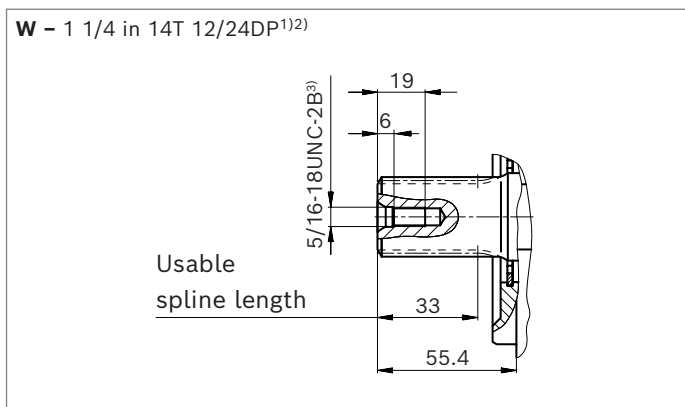
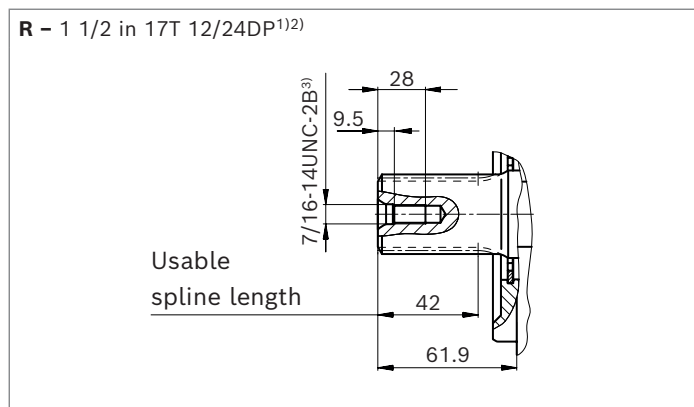

| Port plate ports | | Standard | Size | p_{\max} [bar] ⁴⁾ | State ⁷⁾ |
|----------------------|---|-------------------------|--------------------------------|--------------------------------|---------------------|
| Port plate 10 | | | | | |
| A, B | Working port (high-pressure series) Fastening thread | ISO 6162-2 DIN 13 | 1 in M12 × 1.75; 17 deep | 350 | O |
| Port plate 60 | | | | | |
| A, B | Working port (high-pressure series) Fastening thread | ISO 6162-2 ASME B1.1 | 1 in 7/16-14UNC-2B; 22 deep | 350 | O |
| Other ports | | | | | |
| L | Drain port | ISO 11926 ⁵⁾ | 1 1/16-12UNF-2B; 20 deep | 4 | O ⁶⁾ |
| L₁ | Drain port | ISO 11926 ⁵⁾ | 1 1/16-12UNF-2B; 20 deep | 4 | X ⁶⁾ |
| G | External control pressure (with DG control) | ISO 11926 ⁵⁾ | 7/16-20UNF-2B; 12 deep | 350 | O |
| G₁ | External control pressure (with DG control) | ISO 11926 ⁵⁾ | 7/16-20UNF-2B; 12 deep | 350 | X |
| X | Pilot pressure (with HZ control) | ISO 11926 | 7/16-20UNF-2B; 10 deep | 350 | O |

1) Involute spline according to ANSI B92.1a, 30° pressure angle, flat root, side fit, tolerance class 5
2) Spline runout is a deviation from the ISO 3019-1 standard.
3) Thread according to ASME B1.1
4) Depending on the application, momentary pressure peaks can occur. Keep this in mind when selecting measuring devices and fittings.

5) The countersink may be deeper than specified in the standard.
6) Depending on the installation position, **L** or **L₁** must be connected (see also installation instructions on pages 38 and 39).
7) O = Must be connected (plugged on delivery)
X = Plugged (in normal operation)

▼ **HZ, HZ6** – Two-point control, hydraulic

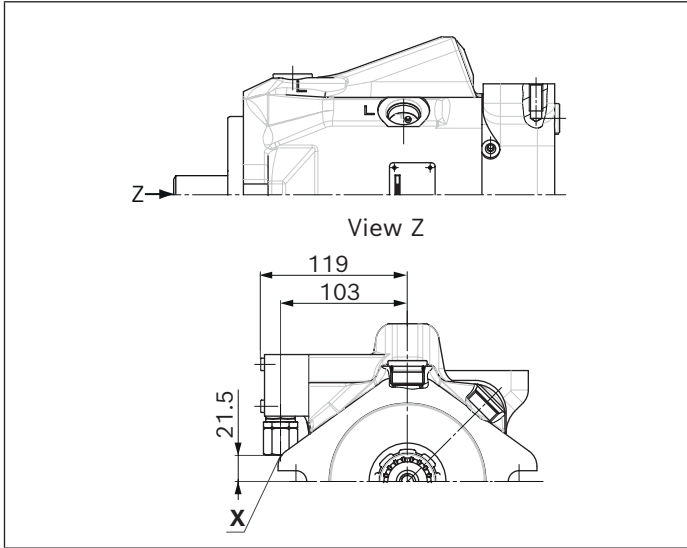

▼ **EZx** – Two-point control, electric

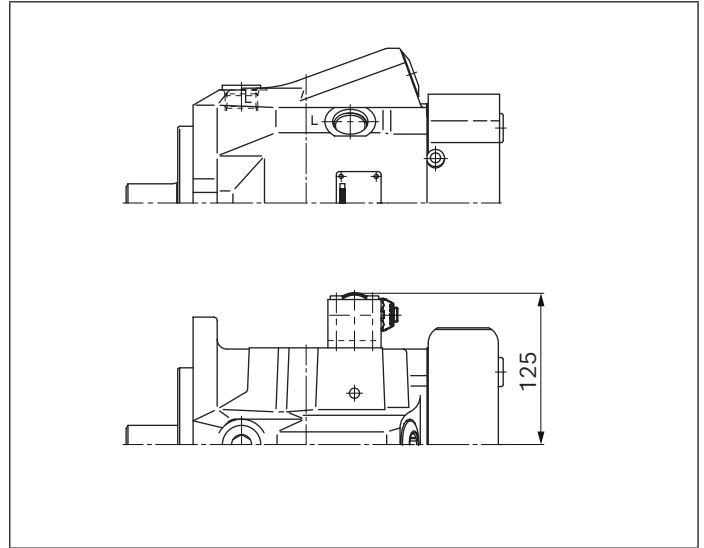

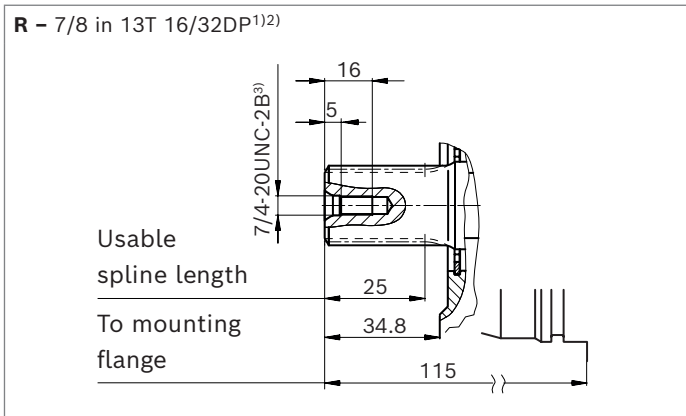
▼ **Splined shaft (similar to ISO 3019-1)**

| Port plate ports | | Standard | Size | p_{\max} [bar] ⁴⁾ | State ⁷⁾ |
|----------------------|---|-------------------------|-------------------------|--------------------------------|---------------------|
| Port plate 10 | | | | | |
| A, B | Working port (high-pressure series) | ISO 6162-2 | 3/4 in | 350 | O |
| | Fastening thread | DIN 13 | M10 × 1.5; 17 deep | | |
| Port plate 60 | | | | | |
| A, B | Working port (high-pressure series) | ISO 6162-2 | 3/4 in | 350 | O |
| | Fastening thread | ASME B1.1 | 3/8-16UNC-2B; 21 deep | | |
| Port plate 16 | | | | | |
| A, B | Working port | DIN 3852-1 | M27 × 2; 16 deep | 350 | O |
| Port plate 66 | | | | | |
| A, B | Working port | ISO 11926 | 1 1/16-12UN-2B; 20 deep | 350 | O |
| Other ports | | | | | |
| L | Drain port | ISO 11926 ⁵⁾ | 3/4-16UNF-2B; 15 deep | 4 | O ⁶⁾ |
| L₁ | Drain port | ISO 11926 ⁵⁾ | 3/4-16UNF-2B; 15 deep | 4 | X ⁶⁾ |
| G | External control pressure (with DG control) | ISO 11926 ⁵⁾ | 7/16-20UNF-2B; 12 deep | 350 | O |
| G₁ | External control pressure (with DG control) | ISO 11926 ⁵⁾ | 7/16-20UNF-2B; 12 deep | 350 | X |
| X | Pilot pressure (with HZ control) | ISO 11926 | 7/16-20UNF-2B; 12 deep | 350 | O |

- 1) Involute spline according to ANSI B92.1a, 30° pressure angle, flat root, side fit, tolerance class 5
- 2) Spline runout is a deviation from the ISO 3019-1 standard.
- 3) Thread according to ASME B1.1
- 4) Depending on the application, momentary pressure peaks can occur. Keep this in mind when selecting measuring devices and fittings.

- 5) The countersink may be deeper than specified in the standard.
- 6) Depending on the installation position, **L** or **L₁** must be connected (see also installation instructions on pages 38 and 39).
- 7) O = Must be connected (plugged on delivery)
X = Plugged (in normal operation)

▼ **HZ, HZ6** – Two-point control, electric

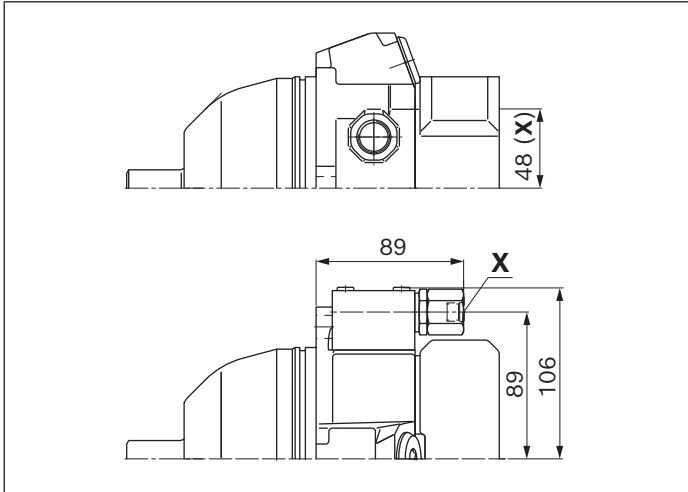

▼ **EZx** – Two-point control, electric

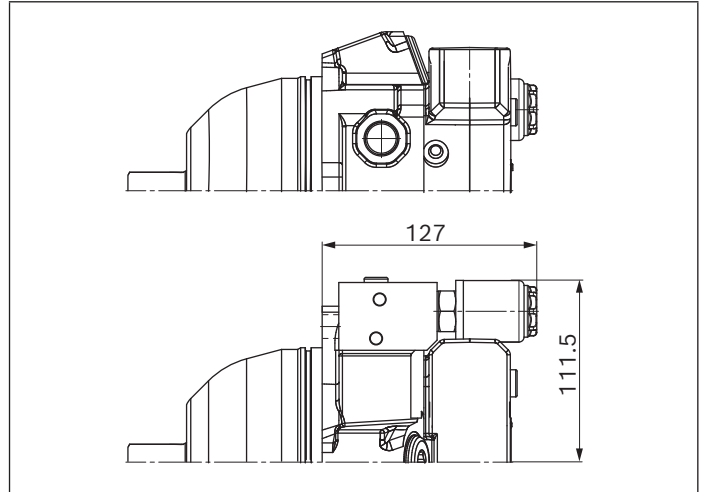

A10VE – Dimensions, size 45

DG – Two-point control, direct operated

Port plate 10 (60), 11 (61) and 16 (66)N000

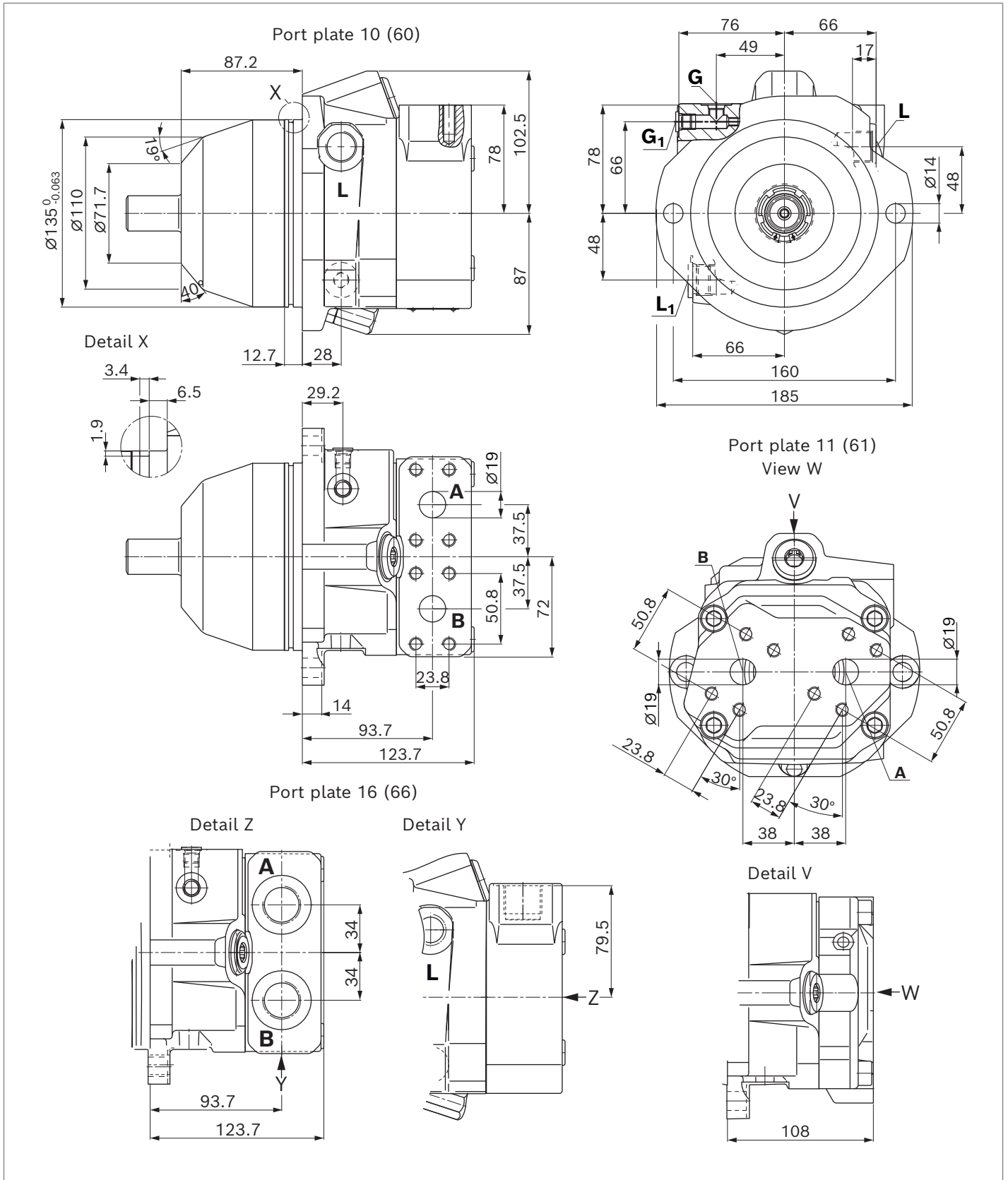

▼ **Splined shaft (similar to ISO 3019-1)**

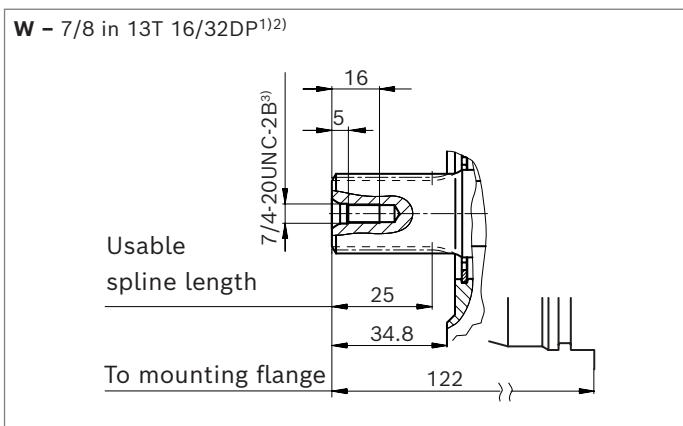
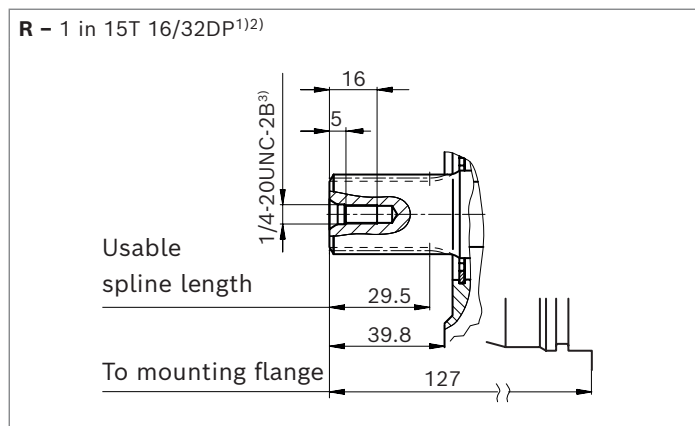

| Port plate ports | | Standard | Size | p_{\max} [bar] ⁴⁾ | State ⁷⁾ |
|--------------------------|---|-------------------------|---------------------------------|--------------------------------|---------------------|
| Port plate 10; 11 | | | | | |
| A, B | Working port (high-pressure series) Fastening thread | ISO 6162-2 DIN 13 | 3/4 in M10 × 1.5; 17 deep | 350 | O |
| Port plate 60; 61 | | | | | |
| A, B | Working port (high-pressure series) Fastening thread | ISO 6162-2 ASME B1.1 | 3/4 in 3/8-16UNC-2B; 21 deep | 350 | O |
| Port plate 16 | | | | | |
| A, B | Working port | DIN 3852-1 | M27 × 2; 16 deep | 350 | O |
| Port plate 66 | | | | | |
| A, B | Working port | ISO 11926 | 1 1/16-12UN-2B; 20 deep | 350 | O |
| Other ports | | | | | |
| L | Drain port | ISO 11926 ⁵⁾ | 7/8-14UNF-2B; 17 deep | 4 | O ⁶⁾ |
| L₁ | Drain port | ISO 11926 ⁵⁾ | 7/8-14UNF-2B; 17 deep | 4 | X ⁶⁾ |
| G | External control pressure (with DG control) | ISO 11926 ⁵⁾ | 7/16-20UNF-2B; 12 deep | 350 | O |
| G₁ | External control pressure (with DG control) | ISO 11926 ⁵⁾ | 7/16-20UNF-2B; 12 deep | 350 | X |
| X | Pilot pressure (with HZ control) | ISO 11926 | 7/16-20UNF-2B; 12 deep | 350 | O |

1) Involute spline according to ANSI B92.1a, 30° pressure angle, flat root, side fit, tolerance class 5
 2) Spline runout is a deviation from the ISO 3019-1 standard.
 3) Thread according to ASME B1.1
 4) Depending on the application, momentary pressure peaks can occur. Keep this in mind when selecting measuring devices and fittings.

5) The countersink may be deeper than specified in the standard.
 6) Depending on the installation position, **L** or **L₁** must be connected (see also installation instructions on pages 38 and 39).
 7) O = Must be connected (plugged on delivery)
 X = Plugged (in normal operation)

▼ **HZ, HZ6** – Two-point control, electric

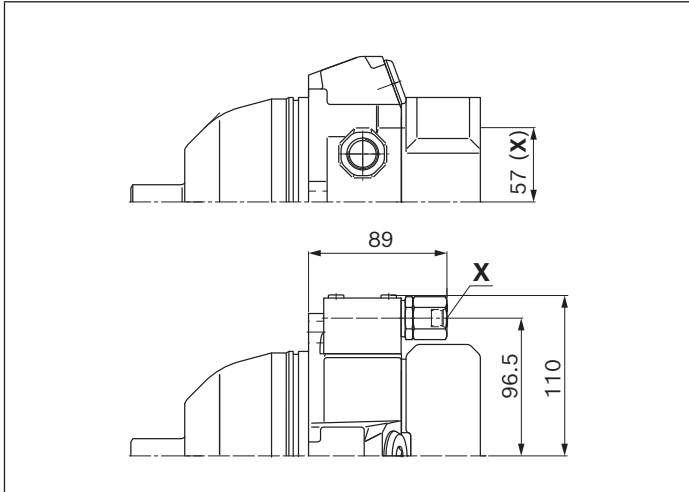

▼ **EZx** – Two-point control, electric

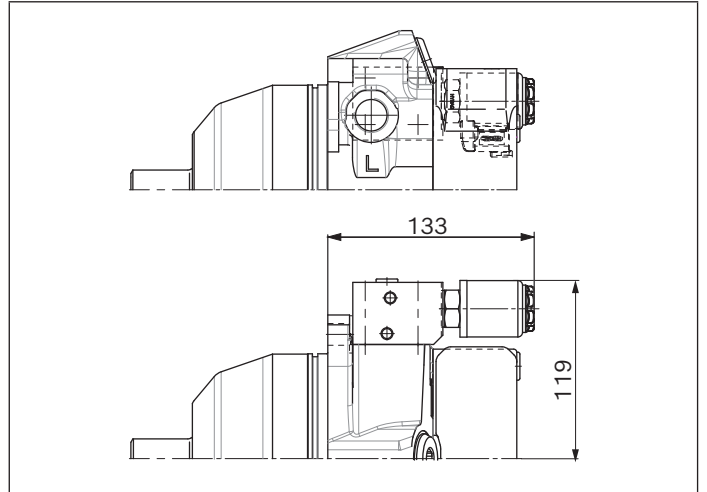

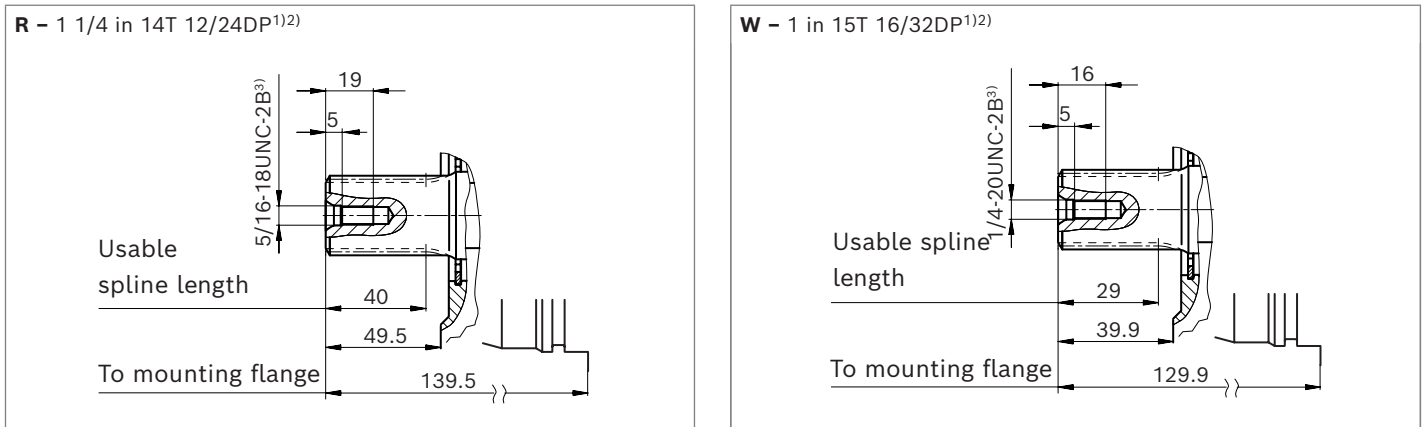
▼ **Splined shaft (similar to ISO 3019-1)**

| Port plate ports | | Standard | Size | p_{\max} [bar] ⁴⁾ | State ⁷⁾ |
|----------------------|---|-------------------------|---------------------------------|--------------------------------|---------------------|
| Port plate 10 | | | | | |
| A, B | Working port (high-pressure series) Fastening thread | ISO 6162-2 DIN 13 | 3/4 in M10 × 1.5; 17 deep | 350 | O |
| Port plate 60 | | | | | |
| A, B | Working port (high-pressure series) Fastening thread | ISO 6162-2 ASME B1.1 | 3/4 in 3/8-16UNC-2B; 21 deep | 350 | O |
| Port plate 16 | | | | | |
| A, B | Working port | DIN 3852-1 | M27 × 2; 16 deep | 350 | O |
| Port plate 66 | | | | | |
| A, B | Working port | ISO 11926 | 1 1/16-12UN-2B; 20 deep | 350 | O |
| Other ports | | | | | |
| L | Drain port | ISO 11926 ⁵⁾ | 7/8-14UNF-2B; 17 deep | 4 | O ⁶⁾ |
| L₁ | Drain port | ISO 11926 ⁵⁾ | 7/8-14UNF-2B; 17 deep | 4 | X ⁶⁾ |
| X | Pilot pressure | ISO 11926 | 7/16-20UNF-2B; 12 deep | 350 | O |

1) Involute spline according to ANSI B92.1a, 30° pressure angle, flat root, side fit, tolerance class 5
 2) Spline runout is a deviation from the ISO 3019-1 standard.
 3) Thread according to ASME B1.1
 4) Depending on the application, momentary pressure peaks can occur. Keep this in mind when selecting measuring devices and fittings.

5) The countersink may be deeper than specified in the standard.
 6) Depending on the installation position, **L** or **L₁** must be connected (see also installation instructions on pages 38 and 39).
 7) O = Must be connected (plugged on delivery)
 X = Plugged (in normal operation)

▼ **EZx** – Two-point control, electric

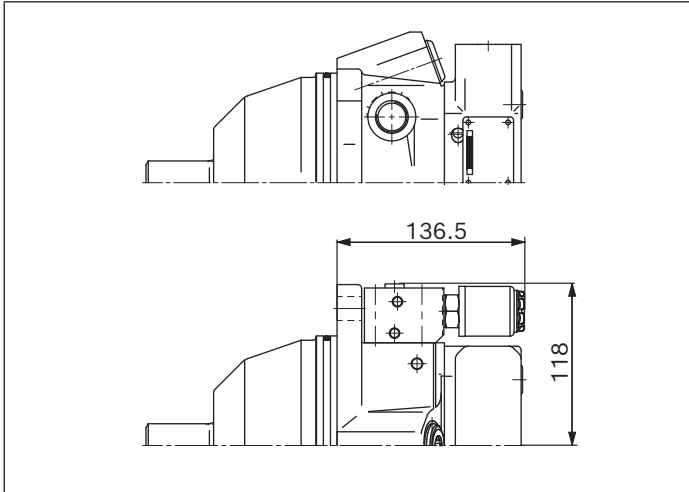

Flushing and boost-pressure valve

Order option ...N007

The flushing and boost-pressure valve is used in a closed circuit to prevent increased heat and to protect the minimum boost pressure (set to 16 bar). The valve is integrated in the port plate.

A quantity of hydraulic fluid determined by an orifice is taken from the respective low-pressure side and discharged into the motor housing. Together with the leakage, it is discharged to the reservoir via the drain port. The hydraulic fluid removed from the circuit must be replaced by the boost pump with cooled hydraulic fluid.

Standard flushing flows

At low pressure $p_{ND} = 20$ bar and orifice of $\varnothing 1.6$ mm, the standard flushing quantity is 5.5 l/min (sizes 28 - 85). Please specify other orifice diameters in plain text.

Other flushing flows:

| Orifice diameter [mm] | Flushing flow [l/min] |
|-----------------------|-----------------------|
| 1.2 | 3.5 |
| 1.6 | 5.5 |
| 1.8 | 7.2 |

▼ Circuit diagram

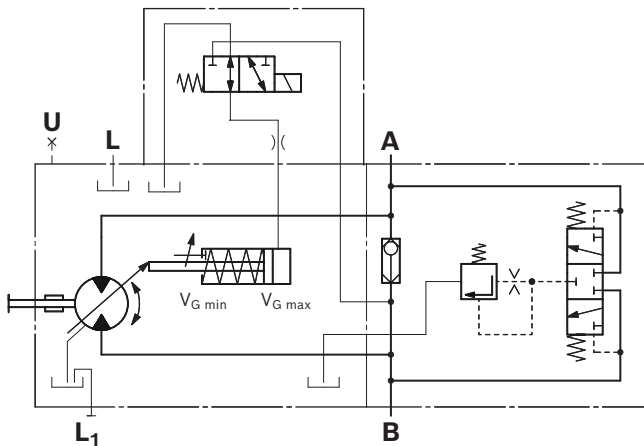

▼ Dimensions A10VM and A10VE

Port plate 10 (60)

Port plate 16 (66)

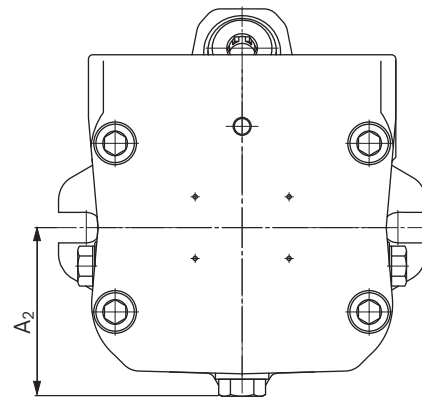
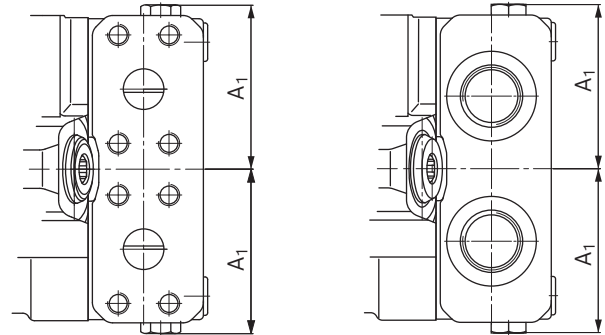

| Size | A ₁ | A ₂ |
|------|----------------|----------------|
| 28 | 72 | 72 |
| 45 | 77 | 77 |
| 63 | 77 | 82 |
| 85 | - | - |

Speed sensing

Order option ...W

The version A10VE...W is prepared for the installation of a speed sensor DST or DSA1/20 and DSA2/20 and is equipped with a spline on the rotary group.

▼ Dimension A10VE prepared for speed sensor

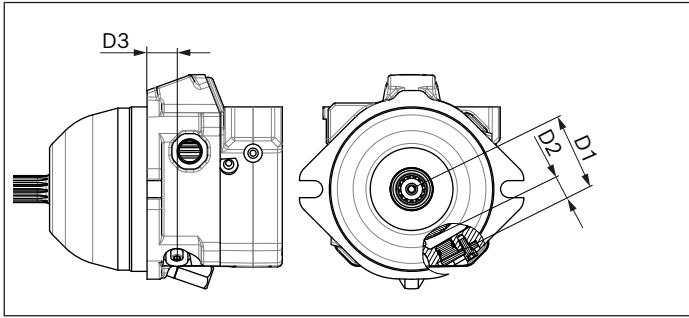

| A10VE | | | | |
|-----------|----|------|------|----|
| Size | | 28 | 45 | 63 |
| D1 | mm | 63 | 68.5 | – |
| D2 | mm | 20.1 | 19.5 | – |
| D3 | mm | 24.5 | 44.7 | – |

Order option ...E, C and K

The mounted speed sensor DST (E) or DSA1/20 (C), DSA2/20 (K) can record both the rotational speed and the direction of rotation of the motor.

Additionally, the sensors also feature an NTC thermistor, which enables measuring the temperature in the installation location of the sensor.

Type code, technical data, dimensions and information on the connector, plus safety instructions about the sensor can be found in the relevant data sheet 95131 (DST) or 95126 (DSAx/20).

▼ Circuit diagram Example A10VE...EZ6

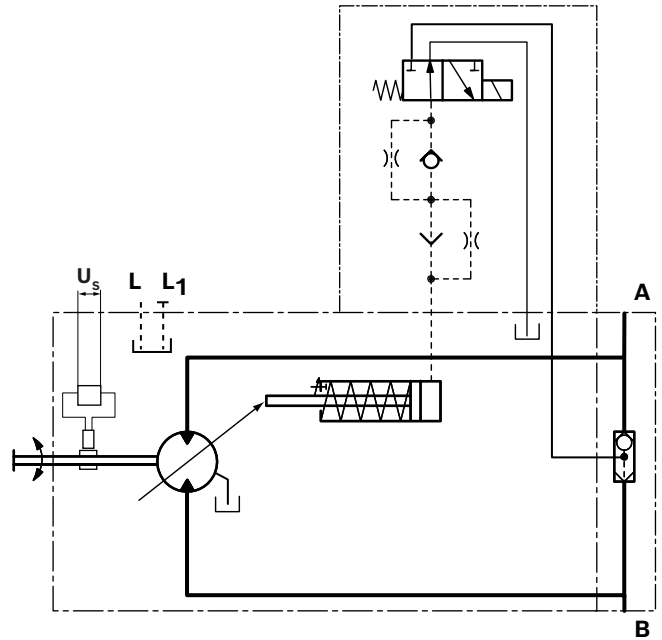

Pin assignment, speed sensor DSA1 and DSA2 Order option C and K

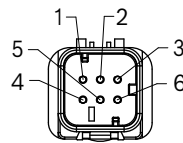

- 1 Supply voltage
- 2 Ground
- 3 S1 frequency
- 4 Direction of rotation
- 5 Temperature sensor
- 6 Temperature sensor

▼ Pin assignment, speed sensor DST order option "E"

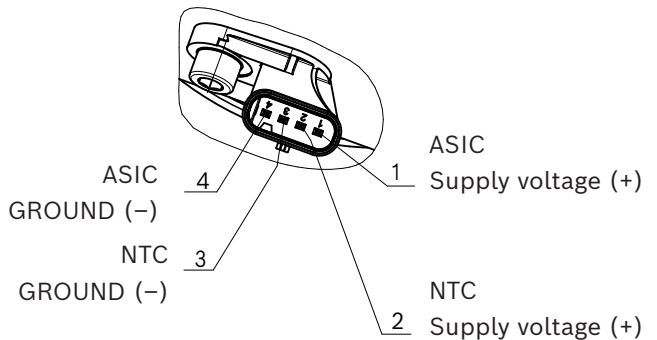

Notice

- ▶ Painting the sensor with electrostatic charge is not permitted (danger: ESD damage)

Electrostatic discharge

ISO 10605:2008

- ▶ Contact discharge (probe touches the sensor) ± 8 kV (sensor operated actively and passively)
- ▶ Air discharge (arc between probe and sensor) ± 15 kV (sensor operated actively and passively)

Dimension A10VE with speed sensor DSAX and DST

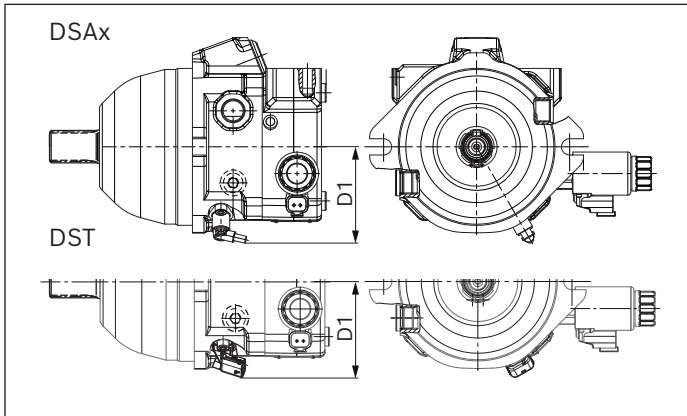

| A10VE | | | | |
|------------------|----|------|------|----|
| Size | | 28 | 45 | 63 |
| D1 / DSAX | mm | 82.8 | 89.2 | – |
| (Code C, K) | | | | |
| D1 / DST | mm | 81.3 | 87.2 | – |
| (Code E) | | | | |

Notice

For dimensions with mating connector, please contact us.

Connector for solenoids

DEUTSCH DT04-2P-EP04

Molded, 2-pin, without bidirectional suppressor diode. There is the following type of protection with the mounted mating connector:

- ▶ IP67 (DIN/EN 60529) and
- ▶ IP69K (DIN 40050-9)

▼ **Switching symbol**

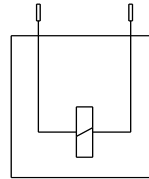

▼ **Mating connector DEUTSCH DT06-2S-EP04**

| Consisting of | DT designation |
|---------------|----------------|
| 1 housing | DT06-2S-EP04 |
| 1 wedge | W2S |
| 2 sockets | 0462-201-16141 |

The mating connector is not included in the scope of delivery.

This can be supplied by Bosch Rexroth on request (material number R902601804).

Notice

- ▶ If necessary, you can change the position of the connector by turning the solenoid body. The procedure is defined in the instruction manual.
- ▶ Only the dead weight (<1 N) of the connection cable with a length of 150 mm may act on the plug-in connection and the solenoid coil with coil nut. Other forces and vibrations are not permissible. For example, this can be realized by suspension of the cable at the same vibration system.

Installation instructions for A10VM

General

The axial piston unit must be filled with hydraulic fluid and air bled during commissioning and operation. This must also be observed following a longer standstill as the axial piston unit may empty via the hydraulic lines. Please contact us regarding the installation position "drive shaft at top or bottom".

The leakage in the housing area must be directed to the reservoir via the highest positioned drain port (**L**, **L₁**). If a shared drain line is used for several units, make sure that the respective case pressure in each unit is not exceeded. The shared drain line must be dimensioned to ensure that the maximum permissible case pressure of all connected units is not exceeded in any operating condition, particularly at cold start. If this is not possible, separate drain line must be laid, if necessary.

To prevent the transmission of structure-borne noise, use elastic elements to decouple all connecting lines from all vibration-capable components (e.g., reservoir, frame parts).

Under all operating conditions, the drain line must flow into the reservoir below the minimum fluid level.

When designing the reservoir, ensure that there is adequate distance between the suction line and the drain line. We recommend using a baffle (baffle plate) between suction line and drain line. A baffle improves the air separation ability as it gives the hydraulic fluid more time for desorption. Apart from that, this prevents the heated return flow from being drawn directly back into the suction line. The suction port must be supplied with air-free, calmed and cooled hydraulic fluid.

Notice

In certain installation positions, an influence on the adjustment or control can be expected. Gravity, dead weight and case pressure can cause minor characteristic shifts and changes in actuating time.

Installation position

See the following examples **1** to **8**.

Further installation positions are available upon request.

Recommended installation position: **1, 3, 5** and **7**

| Key | |
|-------------------------|--|
| F | Filling / Air bleeding |
| L, L₁ | Drain port |
| SB | Baffle (baffle plate) |
| $h_{t\ min}$ | Minimum required immersion depth (200 mm) |
| h_{min} | Minimum required distance to reservoir bottom (100 mm) |

Notice

Port **F** is part of the external piping and must be provided on the customer side to make filling and air bleeding easier.

Below-reservoir installation (standard)

Below-reservoir installation means that the axial piston unit is installed outside of the reservoir below the minimum fluid level.

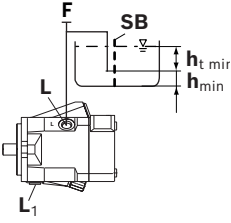
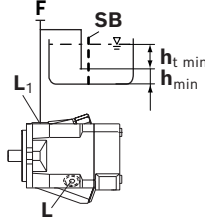
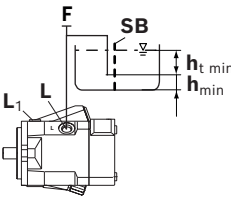
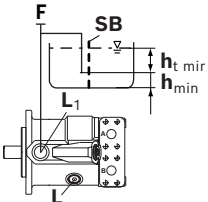
| Installation position A10VM, NG 28 | Air bleed | Filling |
|---|-----------|---------|
| 1 | F, L | F, L |
|  | | |
| 2 | F, L1 | F, L1 |
|  | | |
| Installation position A10VM, NG 45 to 85 | Air bleed | Filling |
| 3 | F, L | F, L |
|  | | |
| 4 | F, L1 | F, L1 |
|  | | |

For key, see page 38

Above-reservoir installation

Above-reservoir installation means that the axial piston unit is installed above the minimum fluid level of the reservoir.

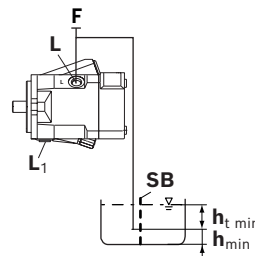
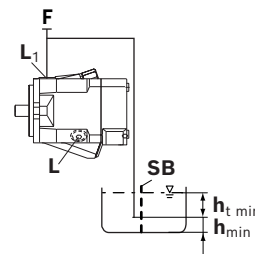
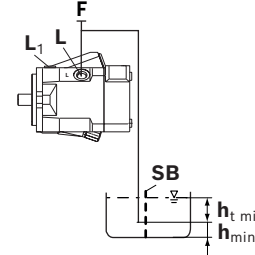
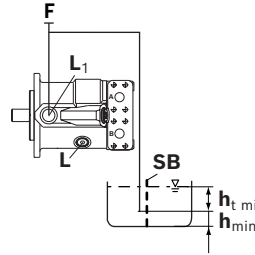
| Installation position NG 28 | Air bleed | Filling |
|--|-----------|---------|
| 5 | F, L | F, L |
|  | | |
| 6 | F, L1 | F, L1 |
|  | | |
| Installation position NG 45 to 85 | Air bleed | Filling |
| 7 | F, L | F, L |
|  | | |
| 8 | F, L1 | F, L1 |
|  | | |

Installation instructions for A10VE

General

The axial piston unit must be filled with hydraulic fluid and air bled during commissioning and operation. This must also be observed following a longer standstill as the axial piston unit may empty via the hydraulic lines. Please contact us regarding the installation position "drive shaft at top or bottom".

The leakage in the housing area must be directed to the reservoir via the highest available drain port (**L**). If this is not possible, separate drain line must be laid.

If a shared drain line is used for several units, make sure that the respective case pressure in each unit is not exceeded. The shared drain line must be dimensioned to ensure that the maximum permissible case pressure of all connected units is not exceeded in any operating condition, particularly at cold start. If this is not possible, separate drain line must be laid, if necessary.

To prevent the transmission of structure-borne noise, use elastic elements to decouple all connecting lines from all vibration-capable components (e.g., reservoir, frame parts).

Under all operating conditions, the drain line must flow into the reservoir below the minimum fluid level.

When designing the reservoir, ensure that there is adequate distance between the suction line and the drain line. We recommend using a baffle (baffle plate) between suction line and drain line. A baffle improves the air separation ability as it gives the hydraulic fluid more time for desorption. Apart from that, this prevents the heated return flow from being drawn directly back into the suction line. The suction port must be supplied with air-free, calmed and cooled hydraulic fluid.

Notice

In certain installation positions, an influence on the adjustment or control can be expected. Gravity, dead weight and case pressure can cause minor characteristic shifts and changes in actuating time.

Installation position

See the following examples **1** to **8**.

Further installation positions are available upon request.

Recommended installation position: **2** and **4**

| Key | |
|-------------------------|--|
| F | Filling / Air bleeding |
| L, L₁ | Drain port |
| SB | Baffle (baffle plate) |
| $h_{t\ min}$ | Minimum required immersion depth (200 mm) |
| h_{min} | Minimum required distance to reservoir bottom (100 mm) |

Notice

Port **F** is part of the external piping and must be provided on the customer side to make filling and air bleeding easier.

Below-reservoir installation (standard)

Below-reservoir installation means that the axial piston unit is installed outside of the reservoir below the minimum fluid level.

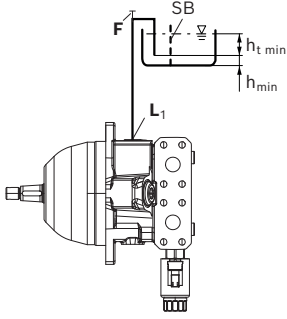
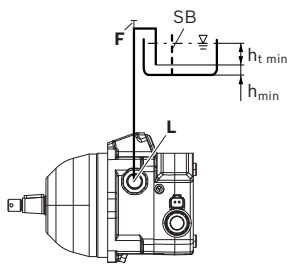
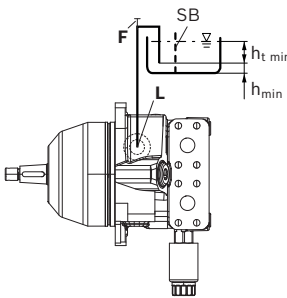
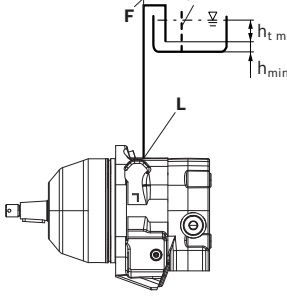
| Installation position NG 18 to 28 | Air bleed | Filling |
|---|--------------------|--------------------|
| 1  | L ₁ (F) | L ₁ (F) |
| 2  | L (F) | L (F) |
| Installation position NG 37 to 45 | Air bleed | Filling |
| 3  | L (F) | L (F) |
| 4  | L (F) | L (F) |

Above-reservoir installation

Above-reservoir installation means that the axial piston unit is installed above the minimum fluid level of the reservoir.

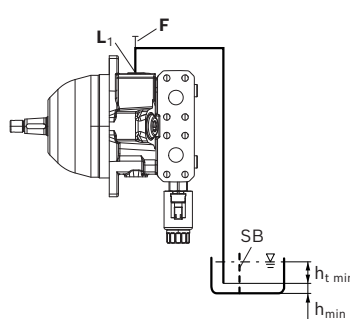
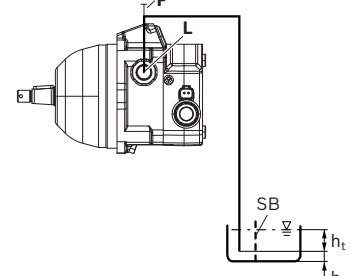
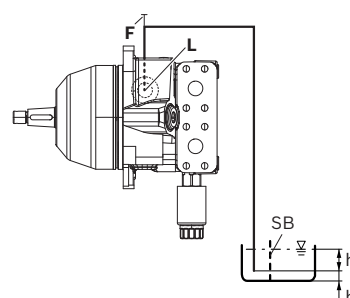
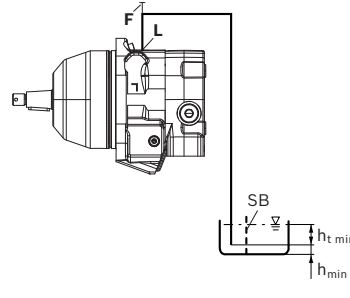
| Installation position NG 18 to 28 | Air bleed | Filling |
|--|--------------------|--------------------|
| 5  | L ₁ (F) | L ₁ (F) |
| 6  | L (F) | L (F) |
| Installation position NG 37 to 45 | Air bleed | Filling |
| 7  | L (F) | L (F) |
| 8  | L (F) | L (F) |

For key, see page 40.

Project planning notes

- ▶ The axial piston variable motor, A10VM and A10VE, is intended to be used in open and closed circuits.
- ▶ Project planning, installation and commissioning of the axial piston units requires the involvement of skilled personnel.
- ▶ Before using the axial piston unit, please read the corresponding instruction manual completely and thoroughly. If necessary, this can be requested from Bosch Rexroth.
- ▶ Before finalizing your design, please request a binding installation drawing.
- ▶ The specified data and notes contained herein must be observed.
- ▶ Depending on the operating conditions of the axial piston unit (working pressure, fluid temperature), the characteristic curve may shift.
- ▶ The characteristic curve may also shift due to the dither frequency or control electronics.
- ▶ Preservation: Our axial piston units are supplied as standard with preservation protection for a maximum of 12 months. If longer preservation protection is required (maximum 24 months), please specify this in plain text when placing your order. The preservation periods apply under optimal storage conditions, details of which can be found in the data sheet 90312 or the instruction manual.
- ▶ Not all versions of the product are approved for use in safety functions according to ISO 13849. Please consult the proper contact at Bosch Rexroth if you require reliability parameters (e.g., $MTTF_d$) for functional safety.
- ▶ Depending on the type of control used, electromagnetic effects can be produced when using solenoids. Use of the recommended direct current (DC) on the electromagnet does not produce any electromagnetic interference (EMI) nor is the electromagnet influenced by EMI. A possible electromagnetic interference (EMI) exists if the solenoid is supplied with modulated direct current (e.g. PWM signal). The machine manufacturer should conduct appropriate tests and take appropriate measures to ensure that other components or operators (e.g. with a pacemaker) are not affected by this potentiality.
- ▶ A pressure relief must be provided in the hydraulic system. In this connection, observe the technical limits of the pressure relief valve.
- ▶ For drives that are operated for a long period of time with constant rotational speed, the natural frequency of the hydraulic system can be stimulated by the excitation frequency of the pump (rotational speed frequency x 9). This can be prevented with suitably designed hydraulic lines.
- ▶ Please note the details regarding the tightening torques of port threads and other threaded joints in the instruction manual.
- ▶ The ports and fastening threads are designed for the p_{max} permissible pressures of the respective ports, see the connection tables. The machine or system manufacturer must ensure that the connecting elements and lines correspond to the specified application conditions (pressure, flow, hydraulic fluid, temperature) with the necessary safety factors.
- ▶ The service ports and function ports are only intended to accommodate hydraulic lines.

Safety instructions

- ▶ During and shortly after operation, there is a risk of burning on the axial piston unit and especially on the solenoids. Take the appropriate safety measures (e.g. by wearing protective clothing).
- ▶ Moving parts in control equipment (e.g. valve spools) can, under certain circumstances, get stuck in position as a result of contamination (e.g. contaminated hydraulic fluid, abrasion, or residual dirt from components). As a result, the hydraulic fluid flow and the build-up of torque in the axial piston unit can no longer respond correctly to the operator's specifications. Even the use of various filter elements (external or internal flow filtration) will not rule out a fault but merely reduce the risk. The machine/system manufacturer must test whether remedial measures are needed on the machine for the application concerned in order to bring the driven consumer into a safe position (e.g., safe stop) and ensure any measures are properly implemented.

Bosch Rexroth AG

An den Kelterwiesen 14
72160 Horb a.N.
Germany
Phone +49 7451 92-0
sales.industry.horb@boschrexroth.de
sales.mobile.horb@boschrexroth.de
www.boschrexroth.com

© Bosch Rexroth AG 2023. All rights reserved, also regarding any disposal, exploitation, reproduction, editing, distribution, as well as in the event of applications for industrial property rights. The data specified within only serve to describe the product. As our products are constantly being further developed, no statements concerning a certain condition or suitability for a certain application can be derived from our information. The information given does not release the user from the obligation of own judgment and verification. It must be remembered that our products are subject to a natural process of wear and aging.