

DF / DFF

Pressure Filter / Pressure Filter for Reversible Oil Flow

Symbol for hydraulic systems:

DF

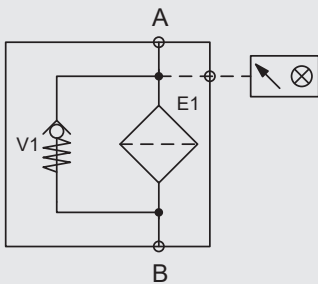

DFF

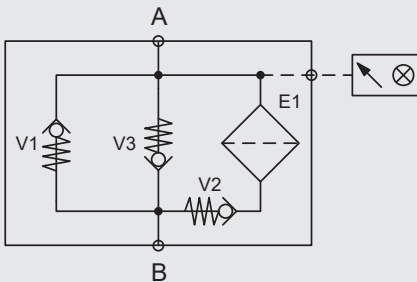

- A Inlet
- B Outlet
- E1 Filter element
- V1 Bypass valve
- V2 Check valve
- V3 Check valve

1. SIZES

DF/DFF...1.X/2.X												DF...3.X					
30	60	110	140	160	240	280	330	500	660	990	1320	1500	330	500	660	990	1320

2. TECHNICAL DATA

Filter specifications

Nominal pressure	420 bar
Maximum flow rate	960 l/min
Temperature range	-30 °C to + 100 °C (-30 °C to -10°C: max. 210 bar)

Material of filter head EN-GJS 400-15,

Material of filter bowl Steel

Clogging indicator

Type	VD
Pressure setting	5.0 bar (DFF: 8.0 bar)

Bypass (optional)

Cracking pressure	6.0 bar
-------------------	---------

Miscellaneous

Seal	NBR (= Perbunan)
Installation	As inline filter with or without reversible oil flow
Special designs and accessories	<ul style="list-style-type: none"> • Seals in FKM • With bypass valve (except for DFF 1500) • Oil drain plug up to DF/DFF 280 • Element top-removable – type code: 3.X (only DF filters 330-1320)
Spare parts	See original spare parts list
Certificates and approvals	On request

3. GENERAL DESCRIPTION

3.1 FILTER HOUSING

Design

The filter housings are designed in accordance with international regulations. They consist of a filter head and a screw-in filter bowl. DFF filters are suitable for flow in both directions.

Standard model

- Connection for a clogging indicator in filter head
- Without bypass valve
- Oil drain plug with pressure release (DF/DFF 330 and above)
- 1 or 2-piece filter bowl available as an option for DF/DFF 280-660
- 2-piece filter bowl standard for DF/DFF 990 and above

3.2 FILTER ELEMENTS

The HYDAC filter elements are validated and their quality is constantly monitored according to the following standards: ISO 2941, ISO 2942, ISO 2943, ISO 3724, ISO 3968, ISO 11170, ISO 16889.

Pressure stability values

Designation	Model code	Collapse pressure
Optimicron®	ON	20 bar
Betamicron®	BH4HC	210 bar
Stainless steel wire mesh	W, W/HC	20 bar

3.3 FATIGUE STRENGTH

The fatigue strength is:

DF 30-1320:	2,000,000 load reversals at nominal pressure
DF 1500:	3,000,000 load reversals at 280 bar 300,000 load reversals at 420 bar

3.4 COMPATIBILITY WITH OPERATING FLUIDS (ISO 2943)

- Hydraulic oils HL to HVLP (DIN 51524)
- Lubrication oils (DIN 51517, API, ACEA, DIN 51515, ISO 6743)
- Compressor oils (DIN 51506)
- Biodegradable operating fluids HETG, HEES, HEPG (VDMA 24568) can only be used with FKM seals
- Fire-resistant fluids HFA, HFB, HFC and HFD (ISO 121922) as well as operating fluids with a high water content (>50% water content) on request

3.5 IMPORTANT INFORMATION

- The filter housings must be earthed e.g. via the system/pipe.
- When using electrical clogging indicators, the electrical power supply to the system must be switched off before removing the clogging indicator connector.

4. MODEL CODE

4.1 FILTER ASSEMBLY

DF ON 1500 T L L 10 D 1 . X /-L24

Filter type

DF, DFF

Filter material

ON Optimicron®
BH/HC Betamicron®
 W stainless steel wire mesh (not possible with version 2.X)
 W/HC stainless steel wire mesh

Size of filter or element

30, 60, 110, 140, 160, 240, 280, 330, 500, 660, 990, 1320, 1500

Operating pressure

T 420 bar

Head design

No details inline filter ports
 L filter ports in L configuration (only DF/DFF 1500)

Type and size of port

Type	Connection	Filter size												
		30	60	110	140	160	240	280	330	500	660	990	1320	1500
B	G ½	●												
C	G ¾		V	V	V									
E	G 1 ¼					V	V	V						
F	G 1 ½								●	●	●	●	●	
G	G 2													●
I	SAE DN 20	●	●	●										
J	SAE DN 32					●	●	●						
L	SAE DN 50								V	V	V	V*	V*	●

*) for DFF no preference

Filtration rating in µm

ON 3, 5, 10, 20
BH/HC 3, 5, 10, 20
 W 25, 50, 100, 200
 W/HC 25, 50, 100, 200

Type of clogging indicator

A with screw plug in indicator port
B visual
 BM visual display with red pin
C electrical
D visual and electrical
 LE visual display, electrical switch at 100% of response pressure
 LZ visual display, electrical switch at 75% and 100% of response pressure

Type code

1 one-piece filter bowl (up to DF/DFF 660)
 2 two-piece filter bowl (DF/DFF 280 and above)
 3 element top-removable (DF/DFF 330-1320)

Modification number

X the latest version is always supplied

Supplementary details

V FKM seal, **no details = NBR seal**
 A. Response pressure (e.g.: A2 = 2 bar), **no details = 5 bar (DF), 8 bar (DFF)**
 B. Bypass cracking pressure (e.g.: **B6 = 6 bar**), **no details = no bypass valve** (bypass not possible for DFF 1500)
 SO184 pressure relief screw/oil drain plug (series DF/DFF 330 and above)
 W suitable for oil-water emulsions HFA, HFC (only required if a clogging indicator is used, or V or W elements)
 SFREE Stat-Free
 L... lamp with corresponding voltage (**24V**, 48V, **110V**, 220V) (CI design: D)
LED 2 LEDs up to 24-volt voltage (CI design: D)
 OE opening contact function
 SO135 for PLC controllers
 DB male connector in acc. with Daimler-Benz (CI design: LZ)
 AV male connector in acc. with Audi, VW (CI design: LZ)
 BO male connector in acc. with BMW, Opel, Ford (CI design: LZ)

Note: Our **preferred models** are highlighted in colour.

4.2 REPLACEMENT ELEMENT

0060 D 010 ON /-V

Size

0030, 0060, 0110, 0140, 0160, 0240, 0280, 0330, 0500, 0660, 0990, 1320, 1500

Version

D

Filtration rating in μm

ON 003, 005, 010, 020

BH4HC 003, 005, 010, 020

W 025, 050, 100, 200

W/HC 025, 050, 100, 200

Filter material

ON, BH4HC, W, W/HC

Supplementary details

V, W (for descriptions, see section 4.1)

4.3 CLOGGING INDICATOR

VD 5 D . X /-L24

Type

VD differential pressure indicator up to 420 bar operating pressure

Response pressure

5 standard for DF filter: 5 bar

8 standard for DFF filter: 8 bar

Design

D see section 4.1

Modification number

X the latest version is always supplied

Supplementary details

L..., LED, V, W (for descriptions, see section 4.1)

5. FILTER CALCULATION

The total pressure drop of a filter at a particular flow rate **Q** and **viscosity** ν consists of the sum of the **housing pressure drop** $\Delta p_{\text{housing}}$ and the **element differential pressure** $\Delta p_{\text{element}}$ and can be calculated as follows:

$$\Delta p_{\text{total}} = \Delta p_{\text{housing}} + \Delta p_{\text{element}}$$

$\Delta p_{\text{housing}}$ [bar] = see performance curves

$$\Delta p_{\text{element}} \text{ [bar]} = Q \text{ [l/min]} \cdot \frac{SK \text{ [mbar / (l/min)]}}{1000} \cdot \frac{\nu \text{ [mm}^2\text{/s]}}{30}$$

SK = gradient coefficient (see section 5.2)

For ease of calculation, our Filter Sizing Program is available free of charge at: www.hydac.com/en/online-tools

5.1 HOUSING CURVES

The housing curves are based on ISO 3968. The housing curves apply to mineral oil with a density of 0.86 kg/dm³ and a kinematic viscosity of 30 mm²/s.

In this case, the differential pressure changes proportionally to the density.

DF 30

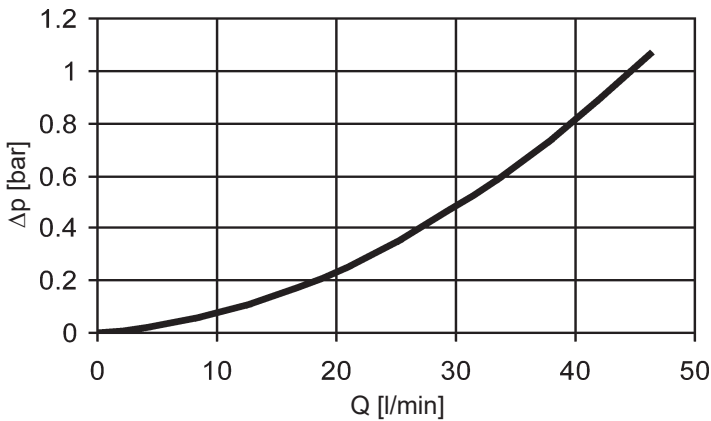

DF 60, 110, 140

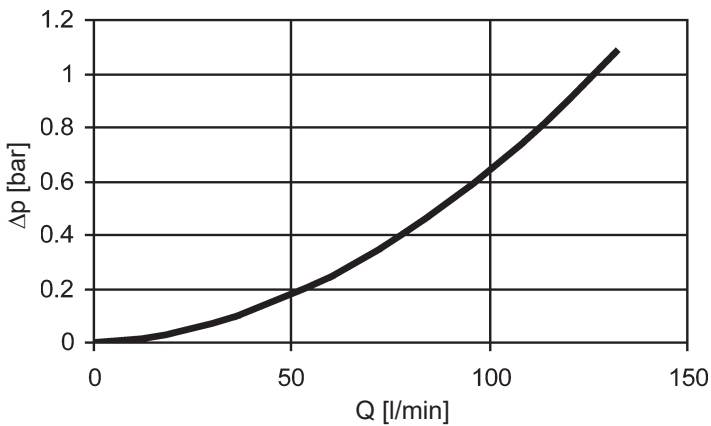

DFF 60, 110, 140

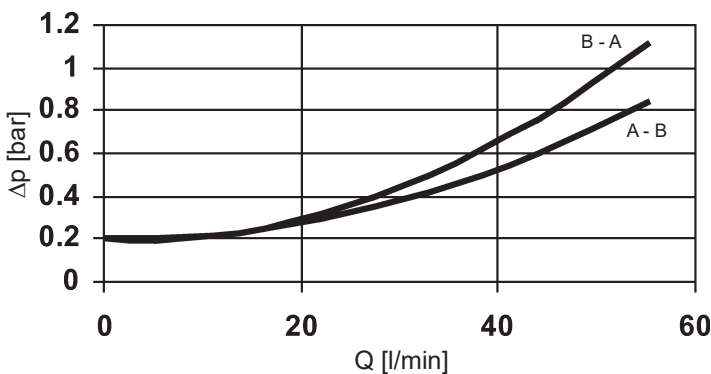

DF 160, 240, 280

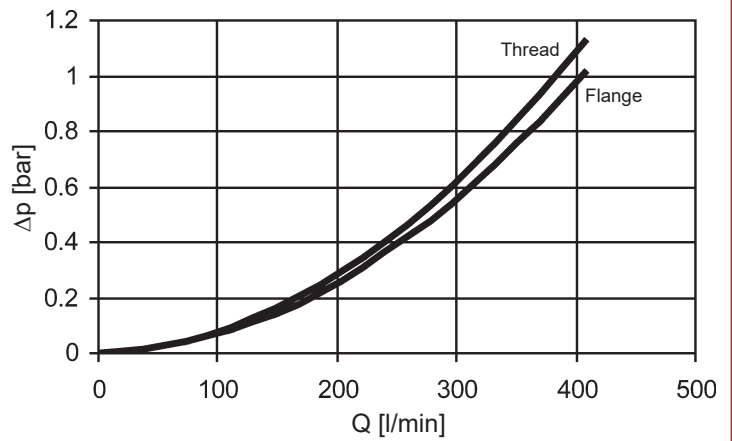

DFF 160, 240, 280

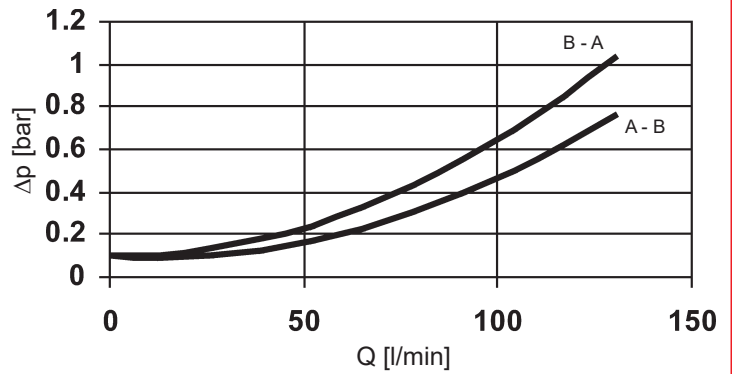

DF 330, 500, 660, 990, 1320

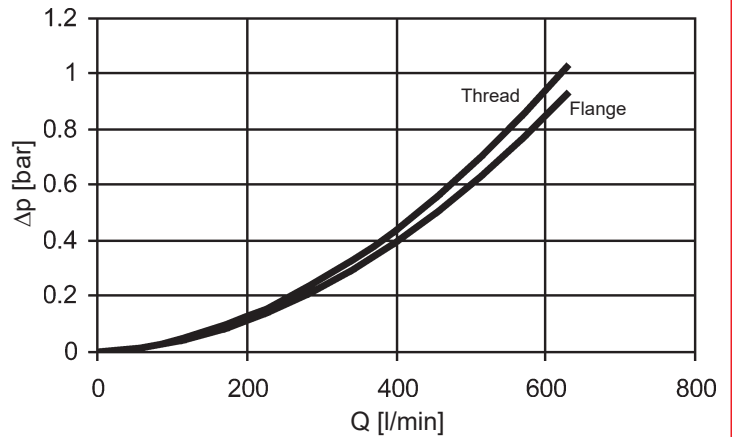

DFF 330, 500, 660, 990, 1320

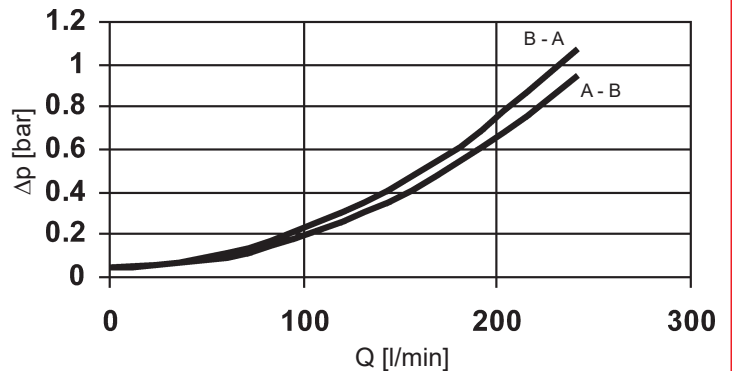

DF 1500

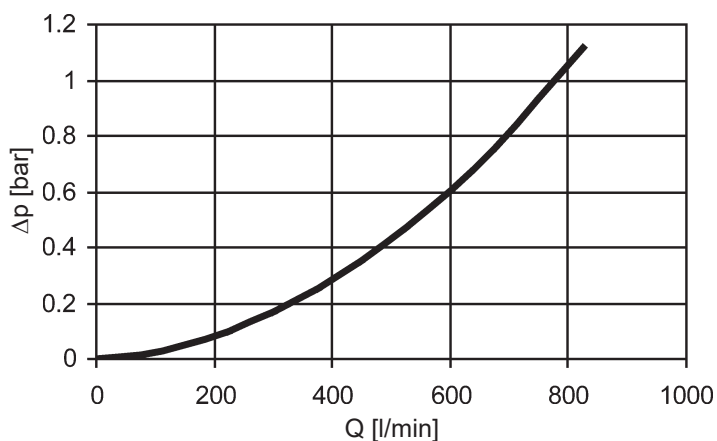

DFF 1500

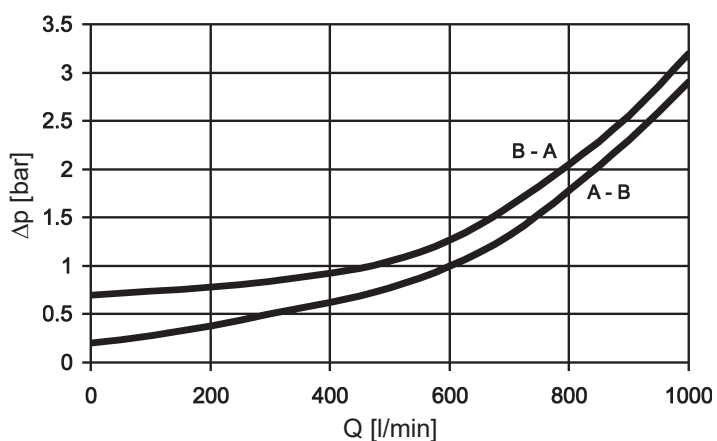

5.2 GRADIENT COEFFICIENTS (SK)

The gradient coefficients in mbar/(l/min) apply to mineral oils with a kinematic viscosity of 30 mm²/s. The pressure drop changes proportionally to the change in viscosity.

Size	ON			
	3 μm	5 μm	10 μm	20 μm
30	63.9	43.3	22.8	11.3
60	26.0	18.3	12.1	6.32
110	13.4	9.61	6.06	2.99
140	11.5	7.39	4.38	2.29
160	11.0	7.70	4.10	3.18
240	6.90	5.34	3.19	2.10
280	3.37	2.74	1.49	1.17
330	4.19	3.37	2.46	1.22
500	2.57	2.07	1.23	0.75
660	1.93	1.56	0.93	0.56
990	1.28	1.03	0.61	0.37
1320	0.97	0.76	0.45	0.27
1500	0.97	0.70	0.48	0.28

Size	BH4HC			
	3 μm	5 μm	10 μm	20 μm
30	91.2	50.7	36.3	19.0
60	58.6	32.6	18.1	12.2
110	25.4	14.9	8.9	5.6
140	19.9	11.3	8.1	4.3
160	16.8	10.4	5.9	4.4
240	10.6	6.8	3.9	2.9
280	5.7	3.4	1.8	1.6
330	7.7	4.5	2.8	2.0
500	4.2	2.6	1.5	1.2
660	3.3	1.9	1.0	0.9
990	2.2	1.3	0.8	0.6
1320	1.6	1.0	0.6	0.4
1500	1.4	0.8	0.6	0.5

Size	W	W/HC
30	3.030	-
60	0.757	0.757
110	0.413	0.413
140	0.324	0.324
160	0.284	0.284
240	0.189	0.189
280	0.162	0.162
330	0.138	0.138
500	0.091	0.091
660	0.069	0.069
990	0.046	0.046
1320	0.035	0.035
1500	0.020	-

5.3 MAXIMUM FLOW RATE

The following maximum permitted flow rates (Q_{max}) in l/min are possible for the various sizes and connection sizes for DF filters (DFF filters on request):

Size	Connector	Q_{max} [l/min]
30	B	30
60	C; I	80
110	C; I	110
140	C; I	120
160	E, J	260
240	E, J	280
280	E, J	360
330	F	380
330	L	450
500	F	460
500	L	570
660	F	500
660	L	610
990	F	520
990	L	660
1320	F	540
1320	L	680
1500	G, L	877
1500	G, L (L flow)	960

Information regarding dimensioning:

The hydraulic load on the filter element is primarily determined by the flow rate and the geometry of the particular filter element. Exceeding the maximum permitted flow rate (Q_{max}) and therefore the permitted hydraulic load can destroy the filter element.

Even the choice of operating medium can influence system performance and lead to problems during use such as electrostatic discharges.

Adherence to the maximum permitted flow rate should always be ensured throughout the system project planning process.

If you have any questions regarding dimensioning or project planning, please contact the technical sales department at HYDAC Filtrertechnik.

6. DIMENSIONS

DF 30, DF/DFE 60 - 1500

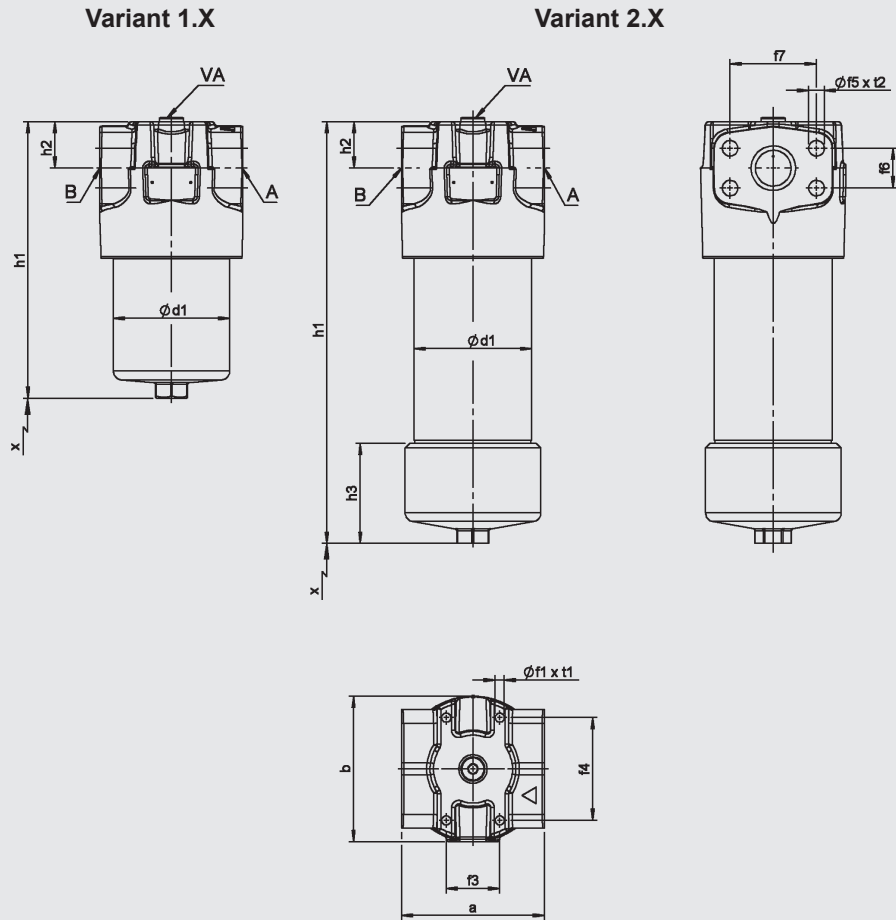

Size		a	b	Ød1	Øf1	f3	f4	Øf5	f6	f7	h1	h2	h3	SW	t1	t2	x	Weight incl. element	Volume of pressure chamber
																		[kg]	[l]
30...	B...	1.X	68	69	52	M5	30	45	-	-	168.5	38	-	24	6	-	75	2.3	0.13
60...	C...	1.X	90	86	68	M6	32	56	-	-	184	40	-	27	9	-	85	4.5	0.2
60...	I...	1.X	89	86	68	M6	32	56	M10	23.8	184	40	-	27	9	15	85	4.5	0.2
110...	C...	1.X	90	86	68	M6	32	56	-	-	253.5	40	-	27	9	-	85	5.4	0.33
110...	I...	1.X	89	86	68	M6	32	56	M10	23.8	253.5	40	-	27	9	15	85	5.4	0.33
140...	C...	1.X	90	86	68	M6	32	56	-	-	294.5	40	-	27	9	-	85	6	0.4
140...	I...	1.X	89	86	68	M6	32	56	M10	23.8	294.5	40	-	27	9	15	85	6	0.4
160...	E...	1.X	125	119	95	M10	35	85	-	-	244	47	-	32	14	-	105	10.3	0.6
160...	J...	1.X	125	119	95	M10	35	85	M14	31.8	244	47	-	32	14	19	105	10.3	0.6
240...	E...	1.X	125	119	95	M10	35	85	-	-	303	47	-	32	14	-	105	11.8	0.8
240...	J...	1.X	125	119	95	M10	35	85	M14	31.8	303	47	-	32	14	19	105	11.8	0.8
280...	E...	1.X	125	119	95	M10	35	85	-	-	485	47	-	32	14	-	105	16.3	1.6
280...	J...	1.X	125	119	95	M10	35	85	M14	31.8	485	47	-	32	14	19	105	16.3	1.6
330...	F...	1.X	160	163	130	M12	60	115	-	-	309.5	52	-	36	17	-	115	24.5	1.5
330...	L...	1.X	160	163	130	M12	60	115	M20	44.5	309.5	52	-	36	17	25	115	24.5	1.5
500...	F...	1.X	160	163	130	M12	60	115	-	-	409.5	52	-	36	17	-	115	28.6	2.3
500...	L...	1.X	160	163	130	M12	60	115	M20	44.5	409.5	52	-	36	17	25	115	28.6	2.3
660...	F...	1.X	160	163	130	M12	60	115	-	-	479	52	-	36	17	-	115	31.6	3
660...	L...	1.X	160	163	130	M12	60	115	M20	44.5	479	52	-	36	17	25	115	31.6	3
330...	F...	2.X	160	163	132	M12	60	115	-	-	306	52	112	36	17	-	180	27.4	1.5
330...	L...	2.X	160	163	132	M12	60	115	M20	44.5	306	52	112	36	17	25	180	27.4	1.5
500...	F...	2.X	160	163	132	M12	60	115	-	-	395	52	112	36	17	-	270	31.5	2.3
500...	L...	2.X	160	163	132	M12	60	115	M20	44.5	395	52	112	36	17	25	270	31.5	2.3
660...	F...	2.X	160	163	132	M12	60	115	-	-	472	52	112	36	17	-	350	34.4	3
660...	L...	2.X	160	163	132	M12	60	115	M20	44.5	472	52	112	36	17	25	350	34.4	3
990...	F...	2.X	160	163	132	M12	60	115	-	-	628	52	112	36	17	-	500	43.4	4.2
990...	L...	2.X	160	163	132	M12	60	115	M20	44.5	628	52	112	36	17	25	500	43.4	4.2
1320...	F...	2.X	160	163	132	M12	60	115	-	-	794	52	112	36	17	-	670	51.1	5.6
1320...	L...	2.X	160	163	132	M12	60	115	M20	44.5	794	52	112	36	17	25	670	51.1	5.6
1500...	G...	2.X	196	176	152	M12	54	110	-	-	884.5	60	122	36	22	-	700	69.3	8.2
1500...	L...	2.X	196	176	152	M12	54	110	M20	44.5	884.5	60	122	36	22	30	700	69.3	8.2

B, C, E, F, G = threaded connection
I, J, L = flange connection to DIN ISO 6162, 6000 psi with metric thread

DF 1500 (filter ports in L configuration)

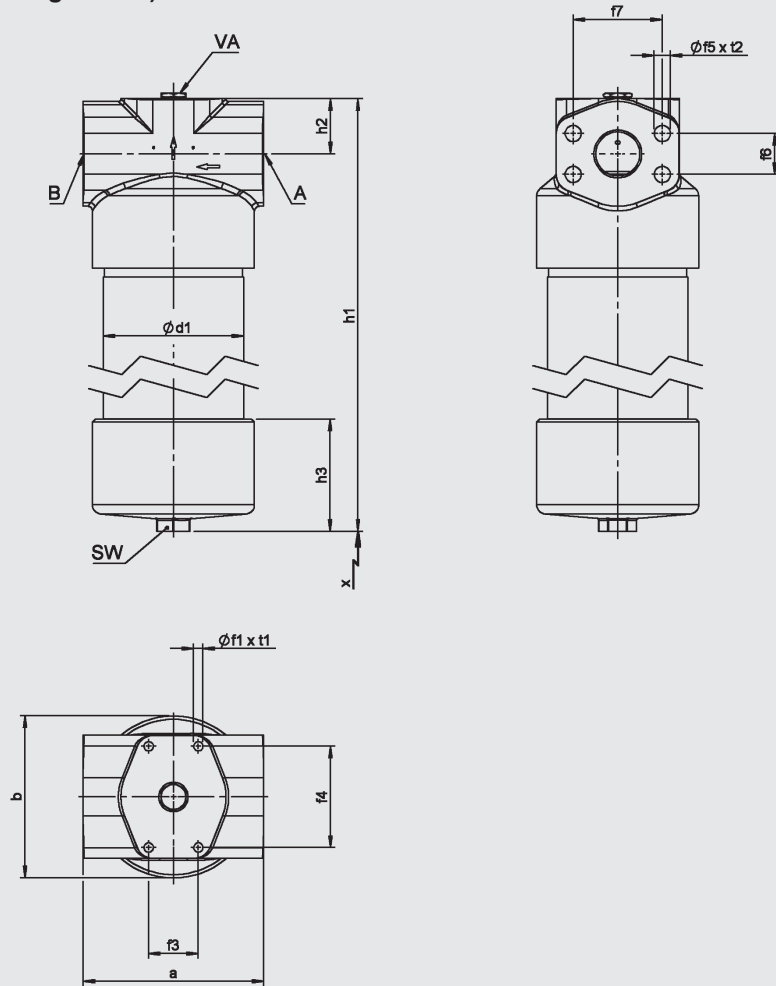

VA = clogging indicator

Size	a	b	Ød1	Øf1	f3	f4	Øf5	f6	f7	h1	h2	h3	SW	t1	t2	x	Weight incl. element [kg]	Volume of pressure chamber [l]
1500... TLG... 2.X	196	176	152	M12	54	110	M20	54	110	888.5	60	122	36	22	30		69.3	8.2
1500... TLL... 2.X																		

DF 330 - 1320...3.X (element top-removable)

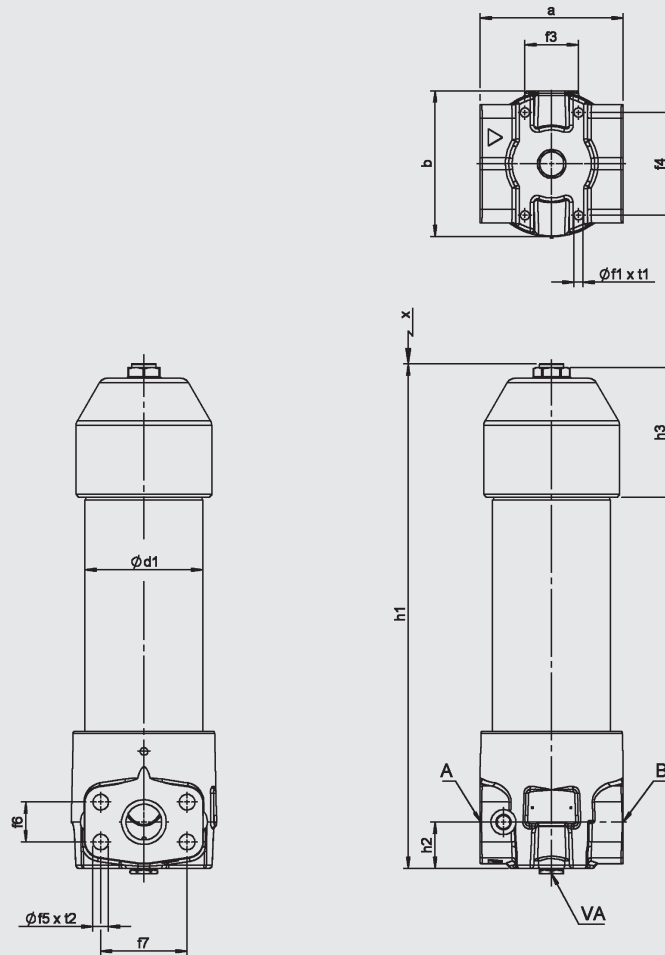

VA = clogging indicator

Size		a	b	Ød1	Øf1	f3	f4	Øf5	f6	f7	h1	h2	h3	SW	t1	t2	x	Weight incl. element	Volume of pressure chamber	
																		[kg]	[l]	
330...	F...	3.X	160	163	132	M12	60	115	-	-	-	366	52	149	36	17	25	80	27.9	1.5
330...	L...	3.X	160	163	132	M12	60	115	M20	44.5	96.8	366	52	149	36	17	25	80	27.9	1.5
500...	F...	3.X	160	163	132	M12	60	115	-	-	-	455	52	149	36	17	25	170	31.8	2.3
500...	L...	3.X	160	163	132	M12	60	115	M20	44.5	96.8	455	52	149	36	17	25	170	31.8	2.3
660...	F...	3.X	160	163	132	M12	60	115	-	-	-	532	52	149	36	17	25	250	33.9	3
660...	L...	3.X	160	163	132	M12	60	115	M20	44.5	96.8	532	52	149	36	17	25	250	33.9	3
990...	F...	3.X	160	163	132	M12	60	115	-	-	-	687	52	149	36	17	25	400	43.1	4.2
990...	L...	3.X	160	163	132	M12	60	115	M20	44.5	96.8	687	52	149	36	17	25	400	43.1	4.2
1320...	F...	3.X	160	163	132	M12	60	115	-	-	-	853	52	149	36	17	25	570	50.8	5.6
1320...	L...	3.X	160	163	132	M12	60	115	M20	44.5	96.8	853	52	149	36	17	25	570	50.8	5.6
1500...	L...	3.X	196	176	152.4	M12	54	110	M20	44.5	96.8	930.5	60	124	36	22	30	700	65	8.2

The information in this brochure relates to the operating conditions and applications described.

For applications and/or operating conditions not described please contact the relevant technical department.

Subject to technical modifications.

HYDAC Filtertechnik GmbH
 Industriegebiet
66280 Sulzbach/Saar, Germany
 Phone: +49 68 97 / 509-01
 Fax: +49 68 97 / 509-300
 Internet: www.hydac.com
 E-mail: filter@hydac.com