

Remote Control Relief Valve

RM Series

Features and Handling

- RM series are Direct type relief valves with three pressure ranges available. They can be used as remote control relief valve when they are connected to the vent port of any balanced piston type relief valves.

- To adjust the set pressure, loosen the lock nut of the valve and turn the handle to adjust the pressure. Maintain the back pressure at the tank port as low as possible, less than 2 bar (28 psi).



Specification

Model	Maximum Flow L/min (USgpm)	Maximum Pressure bar (psi)	Weight kg (lb)
RM-T02	12 (3.2)	240 (3500)	1.5 (3.3)
RM-G02	2 (0.5)		1.4 (3.1)

Symbols

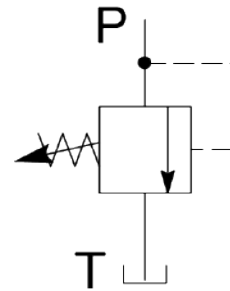

Ordering Code

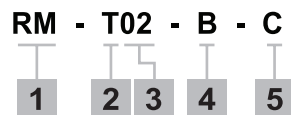

1. Model : RM

2. Mounting

- T - Threaded connections
G - Gasket mounting

3. Valve Size

- 02 - 1/4"

4. Threaded Size (Threaded connections only)

Code	Thread size
N	1/4" NPT
B	1/4" BSP

5. Pressure Range

- A - 7-70 bar (100-1000 psi)
B - 35-140 bar (500-2000 psi)
C - 70-240 bar (1000-3500 psi)

Remote Control Relief Valve RM Series

Installation Dimension mm (inch)

RM-G02

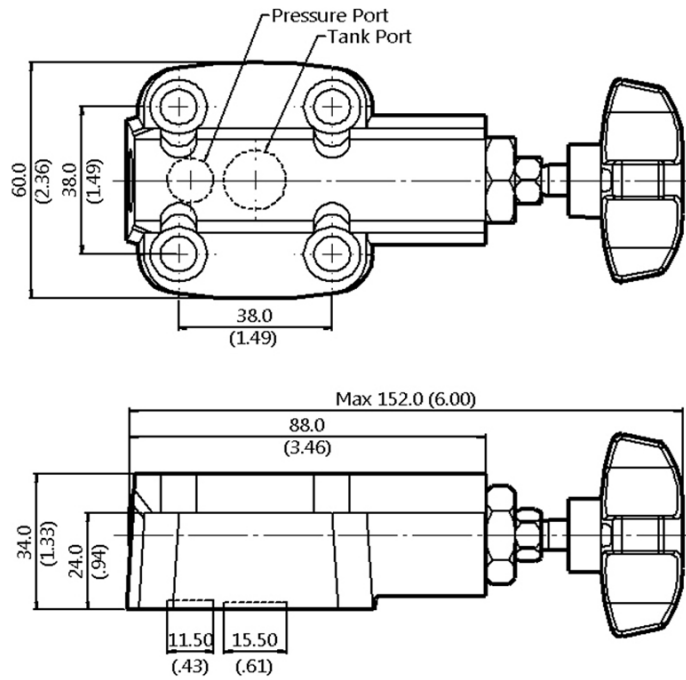

RM-T02

