

# H Series (101-)

## Highlights

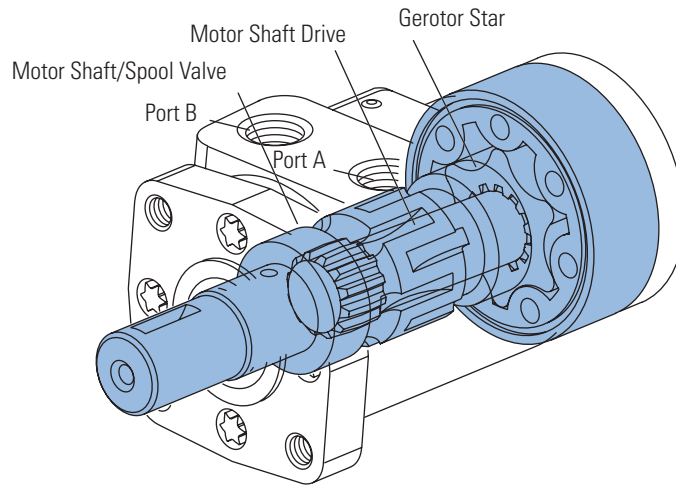

### Description

Designed for medium duty applications, these motors use industry-proven spool valve technology combined with state-of-the-art gerotors. In addition, a wide variety of mounting flanges, shafts, Ports and valving options provide design flexibility. Direction of shaft rotation and shaft speed can be controlled easily and smoothly throughout the speed range of the motor, and equipment can be driven direct, eliminating costly mechanical components.

### Specifications

Gerotor Element	13 Displacements
Flow l/min [GPM]	57 [15] Continuous***
	76 [20] Intermittent**
Speed	Up to 1100 RPM
Pressure bar [PSI]	125 [1800] Cont.***
	165 [2400] Inter.**
Torque Nm [lb-in]	407 [3604] Cont.***
	520 [4600] Inter.**

\*\*\* Continuous—(Cont.) Continuous rating, motor may be run continuously at these ratings.

\*\* Intermittent—(Inter.) Intermittent operation, 10% of every minute.

### Features:

- Time-tested Char-Lynn drive set
- Three moving components (gerotor-star, drive, and shaft)
- Optimized drive running angle
- Three-zone pressure design (inlet, return and case)
- Variety of displacements, shafts and mounts
- Special options to meet customer needs

### Benefits:

- High efficiency
- Powerful compact package
- Design flexibility
- Extended leak-free performance

### Applications:

- Agricultural augers, harvesters, seeders
- Car wash brushes
- Food processing
- Railroad maintenance equipment
- Machine tools
- Conveyors
- Industrial sweepers and floor polishers
- Saw mill works
- Turf equipment
- Concrete and asphalt equipment
- Skid steer attachments
- Many more

B-2



Conveyer



Combine



Sweeper



Salt and Sand Spreader

# H Series (101-)

## Specifications

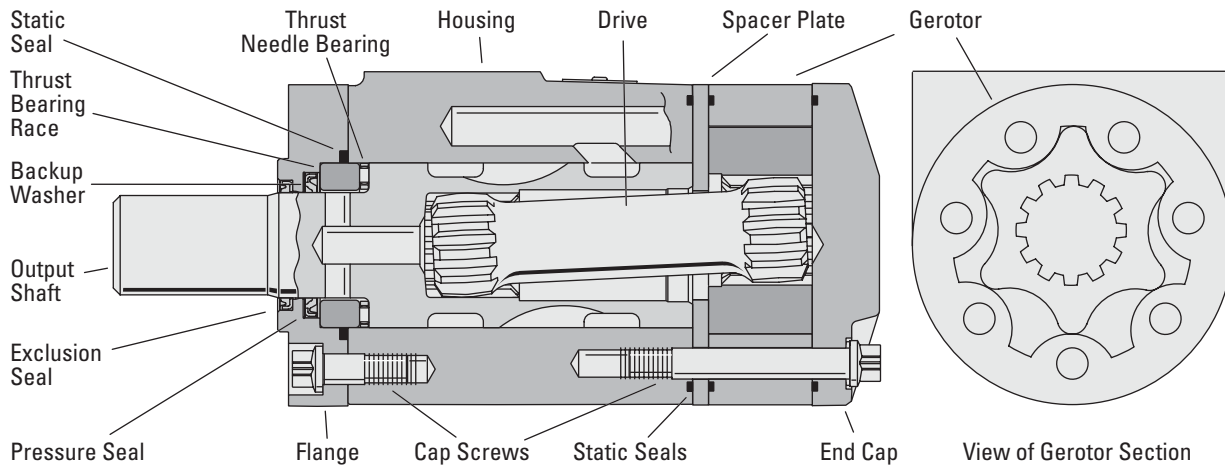

### SPECIFICATION DATA – H MOTORS

Displ. cm <sup>3</sup> /r [in <sup>3</sup> /r]		36 [2.2]	46 [2.8]	59 [3.6]	74 [4.5]	97 [5.9]	120 [7.3]	146 [8.9]	159 [9.7]	185 [11.3]	231 [14.1]	293 [17.9]	370 [22.6]	739 [45.1]
Max. Speed (RPM) @ Continuous Flow		1021	969	953	760	585	469	385	353	304	243	192	152	74
Flow LPM [GPM]	Continuous	38 [10]	45 [12]	57 [15]	57 [15]	57 [15]	57 [15]	57 [15]	57 [15]	57 [15]	57 [15]	57 [15]	57 [15]	57 [15]
	Intermittent	38 [10]	53 [14]	64 [17]	68 [18]	68 [18]	76 [20]	76 [20]	76 [20]	76 [20]	76 [20]	76 [20]	76 [20]	76 [20]
Torque Nm [lb-in]	Continuous	56 [497]	73 [650]	91 [802]	118 [1044]	155 [1368]	192 [1699]	221 [1954]	233 [2059]	265 [2343]	302 [2669]	351 [3110]	407 [3604]	389 [3440]
	Intermittent	75 [668]	99 [876]	122 [1076]	158 [1401]	207 [1829]	257 [2278]	300 [2653]	319 [2824]	356 [3151]	415 [3671]	466 [4121]	484 [4283]	520 [4600]
Min. Starting Torque @ Int. Pressure Nm [lb-in]	@ Cont. Pressure	46 [410]	59 [520]	76 [670]	95 [840]	124 [1100]	154 [1360]	176 [1560]	186 [1650]	211 [1870]	238 [2110]	282 [2500]	330 [2920]	316 [2800]
	@ Int. Pressure	63 [560]	81 [720]	104 [920]	130 [1150]	171 [1510]	2102 [1860]	46 [2180]	262 [2320]	293 [2590]	339 [3000]	388 [3430]	408 [3610]	434 [3840]
Pressure ΔBar [Δ PSI]	Continuous	124 [1800]	124 [1800]	124 [1800]	124 [1800]	124 [1800]	124 [1800]	117 [1700]	114 [1650]	110 [1600]	100 [1450]	93 [1350]	86 [1250]	41 [600]
	Intermittent	165 [2400]	165 [2400]	165 [2400]	165 [2400]	165 [2400]	165 [2400]	159 [2300]	155 [2250]	148 [2150]	138 [2000]	124 [1800]	103 [1500]	55 [800]
End Ported Units Only														
Δ Bar [Δ PSI]	Cont. Pressure	83 [1200]	83 [1200]	76 [1100]	76 [1100]	76 [1100]	69 [1000]	69 [1000]	69 [1000]	62 [900]	55 [800]	48 [700]	57 [825]	27 [396]
	Intermittent	117 [1700]	117 [1700]	110 [1600]	110 [1600]	110 [1600]	103 [1500]	103 [1500]	103 [1500]	91 [1400]	90 [1300]	83 [1200]	68 [990]	36 [528]
Weight kg [lb]		5,1 [11.2]	5,1 [11.2]	5,2 [11.5]	5,2 [11.5]	5,4 [11.8]	5,5 [12.1]	5,6 [12.4]	5,7 [12.5]	5,8 [12.8]	6,0 [13.3]	6,3 [14.0]	6,7 [14.7]	8,4 [18,6]

A simultaneous maximum torque and maximum speed NOT recommended.

#### Note:

To assure best motor life, run motor for approximately one hour at 30% of rated pressure before application to full load. Be sure motor is filled with fluid prior to any load applications.

#### Note:

Δ pressure is derated for end ported units.

#### Maximum Inlet Pressure:

172 Bar [2500 PSI] without regard to Δ Bar [Δ PSI] and/or back pressure ratings or combination thereof.

6B splined or Tapered shafts are recommended whenever operation above 282 NM [2500 lb-in] of torque, especially for those applications subject to frequent reversals.

#### Δ Pressure:

The true Δ bar [Δ PSI] difference between inlet port and outlet port

#### Continuous Rating:

Motor may be run continuously at these ratings

#### Intermittent Operation:

10% of every minute

#### Recommended Fluids:

Recommended Fluids — Premium quality, anti-wear type hydraulic oil. Minimum oil viscosity (at operating temperature) should be the highest of the following:

$$100 \text{ SUS or } \left[ \frac{300 \times \text{Bar}}{\text{RPM}} = \text{SUS} \right]$$

$$\frac{20 \times \text{PSI}}{\text{RPM}} = \text{SUS} \left. \right]$$

#### Recommended System Operating Temp.:

-34°C to 82°C [-30°F to 180°F]

#### Recommended Filtration:



per ISO Cleanliness Code 4406, level 20/18/13

# H Series (101-)

## Performance Data

Motors run with high efficiency in all areas designated with a number for torque and speed, however for best motor life select a motor to run with a torque and speed range printed in the light shaded area.

Performance data is typical at 120 SUS. Actual data may vary slightly from unit to unit in production.

 Continuous  
 Intermittent

36 cm<sup>3</sup>/r [2.2 in<sup>3</sup>/r]  
 Δ Pressure Bar [PSI]  
 Continuous

		[200]	[400]	[600]	[800]	[1000]	[1200]	[1400]	[1600]	[1800]	Max. Continuous	Max. Intermittent
		14	28	41	55	69	83	97	110	124		165
Flow LPM [GPM]	[2]	[49]	[103]	[162]	[189]	[270]	[325]	[379]	[432]	[489]	[650]	[73]
	7.6	6 204	12 201	18 198	21 194	31 189	37 184	43 177	49 170	55 162	73 122	122
	[4]	[47]	[106]	[160]	[191]	[274]	[327]	[384]	[439]	[495]	[654]	[74]
	15.1	5 408	12 407	18 402	22 399	31 394	37 387	43 381	50 373	56 365	74 323	323
	[6]	[44]	[102]	[158]	[188]	[272]	[328]	[383]	[440]	[496]	[661]	[75]
22.7	5 613	12 612	18 609	21 604	31 599	37 591	43 586	50 576	56 565	75 523	523	
[8]	[40]	[97]	[153]	[184]	[270]	[326]	[383]	[440]	[497]	[668]	[75]	
30.3	5 817	11 817	17 814	21 807	31 799	37 793	43 785	50 776	56 762	75 721	721	
[10]	[36]	[90]	[148]	[180]	[265]	[322]	[380]	[438]	[495]	[664]	[75]	
37.9	4 1021	10 1021	17 1015	20 1008	30 1001	36 991	43 981	49 969	56 959	75 920	920	



46 cm<sup>3</sup>/r [2.8 in<sup>3</sup>/r]  
 Δ Pressure Bar [PSI]  
 Continuous

		[200]	[400]	[600]	[800]	[1000]	[1200]	[1400]	[1600]	[1800]	Max. Continuous	Max. Intermittent
		14	28	41	55	69	83	97	110	124		165
Flow LPM [GPM]	[2]	[64]	[136]	[212]	[284]	[355]	[426]	[497]	[567]	[641]	[852]	[96]
	7.6	7 161	15 158	24 156	32 153	40 148	48 145	56 139	64 133	72 127	96 95	95
	[4]	[61]	[139]	[209]	[286]	[359]	[429]	[503]	[576]	[649]	[857]	[97]
	15.1	7 323	16 320	24 316	32 314	41 310	48 304	57 300	65 293	73 287	97 253	253
	[6]	[58]	[134]	[207]	[282]	[356]	[430]	[502]	[577]	[650]	[867]	[98]
22.7	7 486	15 481	23 479	32 475	40 471	49 464	57 461	65 453	73 444	98 410	410	
[8]	[52]	[128]	[200]	[276]	[354]	[428]	[502]	[577]	[651]	[876]	[99]	
30.3	6 648	14 643	23 640	31 635	40 628	48 623	57 617	65 610	74 599	99 566	566	
[10]	[47]	[118]	[194]	[269]	[347]	[423]	[498]	[575]	[649]	[871]	[98]	
37.9	5 808	13 803	22 798	30 793	39 787	48 779	56 771	65 761	73 753	98 722	722	
[12]	[36]	[109]	[188]	[260]	[340]	[417]	[492]	[567]	[643]	[864]	[98]	
45.4	4 969	12 964	21 960	29 952	38 946	47 938	56 931	64 922	73 914	98 877	877	
[14]	[25]	[98]	[175]	[249]	[327]	[404]	[484]	[559]	[634]			
53.0	3 1127	11 1123	20 1115	28 1108	37 1100	46 1093	55 1086	63 1079	72 1068			

# H Series (101-)

## Performance Data

Motors run with high efficiency in all areas designated with a number for torque and speed, however for best motor life select a motor to run with a torque and speed range printed in the light shaded area.

Performance data is typical at 120 SUS. Actual data may vary slightly from unit to unit in production.

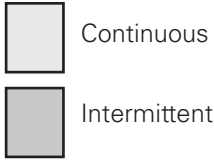

		59 cm <sup>3</sup> /r [3.6 in <sup>3</sup> /r]											
		Δ Pressure Bar [PSI]											
		Continuous											
		[200]	[400]	[600]	[800]	[1000]	[1200]	[1400]	[1600]	[1800]		Max. Continuous	Max. Intermittent
		14	28	41	55	69	83	97	110	124	1800	124	165
Flow LPM [GPM]	[2]	[79]	[169]	[260]	[305]	[437]	[526]	[616]	[704]	[796]	[1055]		
	7,6	9 127	19 125	29 123	34 121	49 117	59 114	70 109	80 103	90 96	119		65
	[4]	[76]	[168]	[257]	[307]	[441]	[529]	[620]	[710]	[800]	[1065]		
	15,1	9 254	19 254	29 251	35 249	50 246	60 241	70 236	80 230	90 224	120		193
	[6]	[73]	[161]	[252]	[303]	[439]	[529]	[618]	[709]	[802]	[1069]		
	22,7	8 381	18 381	28 380	34 377	50 373	60 368	70 364	80 358	91 349	121		319
	[8]	[64]	[151]	[243]	[294]	[428]	[519]	[609]	[701]	[794]	[1076]		
	30,3	7 508	17 508	27 508	33 504	48 500	59 496	69 491	79 484	90 476	122		446
	[10]	[57]	[141]	[234]	[283]	[419]	[512]	[602]	[693]	[786]	[1071]		
	37,9	6 635	16 635	26 634	32 630	47 626	58 621	68 614	78 608	89 601	121		571
	[12]	[45]	[131]	[227]	[274]	[409]	[505]	[593]	[684]	[778]	[1058]		
	45,4	5 762	15 762	26 762	31 757	46 753	57 747	67 741	77 734	88 728	120		694
	[14]	[33]	[118]	[213]	[266]	[396]	[492]	[583]	[676]	[770]	[1055]		
	53,0	4 889	13 889	24 887	30 882	45 877	56 872	66 866	76 860	87 851	119		813
	Max. Continuous	[15]	[29]	[111]	[205]	[260]	[389]	[486]	[576]	[670]	[765]	[1055]	
	56,8	3 953	13 953	23 951	29 945	44 940	55 935	65 929	76 921	86 913	119		872
Max. Intermittent	[20]	[17]	[98]	[192]	[252]	[377]	[475]	[567]	[660]	[757]			
	75,7	2 1080	11 1080	22 1077	28 1071	43 1067	54 1062	64 1055	75 1049	86 1040			



		74 cm <sup>3</sup> /r [4.5 in <sup>3</sup> /r]											
		Δ Pressure Bar [PSI]											
		Continuous											
		[200]	[400]	[600]	[800]	[1000]	[1200]	[1400]	[1600]	[1800]		Max. Continuous	Max. Intermittent
		14	28	41	55	69	83	97	110	124	1800	124	165
Flow LPM [GPM]	[2]	[103]	[220]	[339]	[454]	[569]	[685]	[801]	[916]	[1036]	[1373]		
	7,6	12 101	25 99	38 98	51 96	64 93	77 90	91 86	103 81	117 76	155		51
	[4]	[99]	[219]	[335]	[457]	[574]	[689]	[808]	[925]	[1042]	[1386]		
	15,1	11 203	25 201	38 199	52 197	65 194	78 191	91 187	105 182	118 177	157		153
	[6]	[94]	[210]	[328]	[451]	[571]	[689]	[805]	[924]	[1044]	[1392]		
	22,7	11 305	24 303	37 301	51 298	65 296	78 292	91 288	104 283	118 276	157		252
	[8]	[86]	[196]	[319]	[438]	[558]	[676]	[793]	[913]	[1033]	[1401]		
	30,3	10 406	22 404	36 402	49 399	63 396	76 393	90 388	103 383	117 377	158		352
	[10]	[74]	[183]	[310]	[422]	[545]	[667]	[784]	[903]	[1024]	[1394]		
	37,9	8 507	21 505	35 502	48 499	62 496	75 492	89 486	102 482	116 476	158		452
	[12]	[58]	[171]	[295]	[408]	[533]	[657]	[773]	[891]	[1013]	[1377]		
	45,4	7 608	19 606	33 603	46 600	60 596	74 591	87 587	101 581	114 576	156		549
	[14]	[43]	[154]	[277]	[396]	[515]	[640]	[760]	[880]	[1002]	[1374]		
	53,0	5 709	17 706	31 702	45 698	58 694	72 691	86 686	99 681	113 674	155		643
	Max. Continuous	[15]	[36]	[145]	[268]	[387]	[506]	[632]	[750]	[873]	[996]	[1373]	
	56,8	4 760	16 757	30 753	44 749	57 744	71 740	85 735	99 729	113 723	155		690
Max. Intermittent	[20]	[14]	[121]	[233]	[351]	[482]	[609]	[725]	[856]	[981]			
	75,7	2 904	14 902	26 898	40 895	54 891	69 887	82 882	97 877	111 869			

# H Series (101-)

## Performance Data

Motors run with high efficiency in all areas designated with a number for torque and speed, however for best motor life select a motor to run with a torque and speed range printed in the light shaded area.

Performance data is typical at 120 SUS. Actual data may vary slightly from unit to unit in production.

Continuous  
 Intermittent

		97 cm <sup>3</sup> /r [5.9 in <sup>3</sup> /r] Δ Pressure Bar [PSI] Continuous								Max. Continuous	Max. Intermittent
		[200]	[400]	[600]	[800]	[1000]	[1200]	[1400]	[1600]	[1800]	[2400]
		14	28	41	55	69	83	97	110	124	165
Flow LPM [GPM]	[2] 7,6	[134] 15 78	[292] 33 76	[442] 50 75	[593] 67 73	[746] 84 71	[899] 102 68	[1054] 119 65	[1209] 137 61	[1365] 154 55	[1806] 204 33
	[4] 15,1	[131] 15 156	[281] 32 155	[436] 49 153	[596] 67 151	[750] 85 149	[903] 102 147	[1059] 120 143	[1212] 137 139	[1367] 154 134	[1828] 207 113
	[6] 22,7	[126] 14 234	[269] 30 233	[425] 48 231	[588] 66 230	[747] 84 228	[900] 102 224	[1054] 119 221	[1206] 136 217	[1368] 155 210	[1823] 206 189
	[8] 30,3	[110] 12 312	[246] 28 311	[408] 46 310	[566] 64 308	[718] 81 305	[873] 99 303	[1023] 116 300	[1177] 133 295	[1339] 151 291	[1829] 207 269
	[10] 37,9	[96] 11 390	[231] 26 389	[392] 44 387	[539] 61 385	[699] 79 383	[859] 97 380	[1005] 114 376	[1156] 131 373	[1318] 149 368	[1821] 206 346
	[12] 45,4	[77] 9 468	[218] 25 467	[378] 43 465	[522] 59 463	[681] 77 460	[844] 95 457	[990] 112 453	[1142] 129 449	[1301] 147 445	[1792] 202 421
	[14] 53,0	[60] 7 546	[197] 22 544	[358] 40 542	[513] 58 539	[662] 75 537	[828] 94 535	[973] 110 531	[1131] 128 526	[1293] 146 521	[1776] 201 499
	Max. Continuous 56,8	[52] 6 585	[189] 21 583	[346] 39 581	[495] 56 578	[651] 74 575	[819] 93 573	[963] 109 569	[1126] 127 564	[1286] 145 559	[1778] 201 536
	Max. Intermittent 75,7	[25] 3 701	[157] 18 700	[311] 35 697	[455] 51 694	[625] 71 691	[790] 89 688	[941] 106 684	[1110] 125 681	[1272] 144 674	

} Torque [lb-in]  
 } Nm  
 } Speed RPM

		120 cm <sup>3</sup> /r [7.3 in <sup>3</sup> /r] Δ Pressure Bar [PSI] Continuous								Max. Continuous	Max. Intermittent
		[200]	[400]	[600]	[800]	[1000]	[1200]	[1400]	[1600]	[1800]	[2400]
		14	28	41	55	69	83	97	110	124	165
Flow LPM [GPM]	[2] 7,6	[162] 18 62	[357] 40 61	[544] 61 61	[736] 83 59	[927] 105 58	[1116] 126 55	[1305] 147 53	[1498] 169 49	[1687] 191 45	[2231] 252 26
	[4] 15,1	[160] 18 125	[348] 39 124	[539] 61 123	[736] 83 121	[930] 105 120	[1119] 126 119	[1316] 149 116	[1506] 170 114	[1698] 192 110	[2268] 256 90
	[6] 22,7	[155] 18 188	[338] 38 187	[530] 60 186	[729] 82 185	[923] 104 183	[1116] 126 180	[1310] 148 178	[1500] 169 175	[1699] 192 170	[2271] 257 152
	[8] 30,3	[139] 16 250	[319] 36 250	[515] 58 249	[710] 80 247	[901] 102 245	[1094] 124 243	[1283] 145 241	[1476] 167 237	[1673] 189 233	[2278] 257 216
	[10] 37,9	[121] 14 313	[303] 34 312	[497] 56 311	[686] 78 309	[883] 100 308	[1081] 122 306	[1267] 143 302	[1460] 165 300	[1655] 187 296	[2268] 256 278
	[12] 45,4	[102] 12 375	[288] 33 374	[480] 54 373	[664] 75 371	[862] 97 370	[1060] 120 367	[1246] 141 365	[1440] 163 361	[1640] 185 358	[2232] 252 338
	[14] 53,0	[78] 9 438	[263] 30 437	[458] 52 435	[652] 74 433	[841] 95 431	[1041] 118 430	[1228] 139 427	[1420] 160 423	[1616] 183 419	[2213] 250 401
	Max. Continuous 56,8	[67] 8 469	[253] 29 468	[446] 50 466	[632] 71 464	[828] 94 462	[1030] 116 460	[1214] 137 458	[1411] 159 454	[1608] 182 450	[2205] 249 430
	Max. Intermittent 75,7	[20] 2 626	[202] 23 624	[384] 43 621	[581] 66 618	[778] 88 617	[971] 110 614	[1169] 132 611	[1356] 153 609	[1559] 176 606	

# H Series (101-)

## Performance Data

Motors run with high efficiency in all areas designated with a number for torque and speed, however for best motor life select a motor to run with a torque and speed range printed in the light shaded area.

Performance data is typical at 120 SUS. Actual data may vary slightly from unit to unit in production.

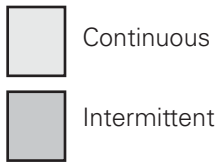

		146 cm <sup>3</sup> /r [8.9 in <sup>3</sup> /r] Δ Pressure Bar [PSI] Continuous									Max. Continuous	Max. Intermittent
		[200]	[400]	[600]	[800]	[1000]	[1200]	[1400]	[1600]	[1700]		[2300]
		14	28	41	55	69	83	97	110	117		159
Flow LPM [GPM]	[2] 7,6	[198] 22 51	[435] 49 50	[664] 75 50	[897] 101 49	[1130] 128 47	[1361] 154 45	[1591] 180 43	[1827] 206 40	[1942] 219 39	[2611] 295 24	
	[4] 15,1	[196] 22 103	[424] 48 102	[657] 74 101	[898] 101 99	[1133] 128 99	[1365] 154 97	[1604] 181 95	[1836] 207 93	[1954] 221 92	[2648] 299 78	
	[6] 22,7	[189] 21 154	[412] 47 153	[646] 73 152	[889] 100 151	[1125] 127 150	[1361] 154 148	[1598] 181 146	[1829] 207 143	[1951] 220 141	[2653] 300 128	
	[8] 30,3	[169] 19 205	[389] 44 205	[628] 71 204	[866] 98 203	[1098] 124 201	[1333] 151 200	[1564] 177 197	[1799] 203 195	[1919] 217 193	[2649] 299 180	
	[10] 37,9	[148] 17 257	[369] 42 256	[605] 68 255	[836] 94 253	[1076] 122 252	[1318] 149 251	[1544] 174 248	[1780] 201 246	[1899] 215 244	[2789] 315 231	
	[12] 45,4	[125] 14 308	[351] 40 307	[586] 66 306	[810] 92 305	[1051] 119 303	[1293] 146 301	[1519] 172 299	[1756] 198 296	[1878] 212 295	[2606] 294 281	
	[14] 53,0	[95] 11 359	[321] 36 358	[558] 63 357	[795] 90 355	[1026] 116 354	[1290] 146 352	[1497] 169 350	[1731] 196 347	[1851] 209 346	[2580] 292 331	
	Max. Continuous 56,8	[82] 9 85	[308] 35 384	[544] 61 383	[771] 87 381	[1010] 114 379	[1256] 142 378	[1480] 167 375	[1720] 194 373	[1840] 208 371	[2569] 290 356	
	Max. Intermittent 75,7	[24] 3 513	[246] 28 512	[468] 53 509	[708] 80 507	[948] 107 506	[1184] 134 504	[1425] 161 501	[1653] 187 499	[1780] 201 498		

		159 cm <sup>3</sup> /r [9.7 in <sup>3</sup> /r] Δ Pressure Bar [PSI] Continuous									Max. Continuous	Max. Intermittent
		[200]	[400]	[600]	[800]	[1000]	[1200]	[1400]	[1600]	[1650]		[2250]
		14	28	41	55	69	83	97	110	134		155
Flow LPM [GPM]	[2] 7,6	[209] 24 47	[465] 53 46	[715] 81 46	[973] 110 45	[1228] 139 44	[1478] 167 42	[1724] 195 40	[1981] 224 38	[2046] 231 37	[2764] 312 23	
	[4] 15,1	[210] 24 94	[460] 52 94	[710] 80 93	[971] 110 91	[1229] 139 91	[1480] 167 90	[1745] 197 89	[1996] 226 87	[2059] 233 87	[2813] 318 76	
	[6] 22,7	[205] 23 141	[454] 51 141	[704] 80 140	[965] 109 139	[1216] 137 138	[1477] 167 136	[1738] 196 134	[1991] 225 132	[2055] 232 132	[2824] 319 119	
	[8] 30,3	[186] 21 188	[440] 50 188	[693] 78 187	[951] 107 186	[1205] 136 185	[1461] 165 183	[1716] 194 181	[1973] 223 179	[2038] 230 178	[2808] 317 166	
	[10] 37,9	[164] 19 235	[422] 48 234	[671] 76 234	[930] 105 232	[1189] 134 232	[1451] 164 230	[1702] 192 228	[1965] 219 226	[2032] 230 225	[2789] 315 213	
	[12] 45,4	[144] 16 282	[404] 46 281	[652] 74 281	[900] 102 279	[1163] 131 279	[1421] 161 277	[1674] 189 275	[1937] 219 273	[2004] 226 272	[2770] 313 260	
	[14] 53,0	[109] 12 330	[374] 42 329	[623] 70 328	[883] 100 327	[1140] 129 325	[1396] 158 323	[1653] 187 322	[1900] 215 319	[1963] 222 319	[2727] 308 306	
	Max. Continuous 56,8	[92] 10 353	[359] 41 352	[612] 69 351	[861] 97 350	[1123] 127 348	[1381] 156 347	[1633] 185 345	[1886] 213 343	[1950] 220 342	[2712] 306 330	
	Max. Intermittent 75,7	[26] 3 471	[268] 30 470	[510] 58 467	[772] 87 465	[1034] 117 464	[1290] 146 462	[1553] 175 460	[1802] 204 458	[1865] 211 458		





# H Series (101-)

## Performance Data

Motors run with high efficiency in all areas designated with a number for torque and speed, however for best motor life select a motor to run with a torque and speed range printed in the light shaded area.

Performance data is typical at 120 SUS. Actual data may vary slightly from unit to unit in production.

 Continuous  
 Intermittent

		185 cm <sup>3</sup> /r [11.3 in <sup>3</sup> /r]									
		Δ Pressure Bar [PSI]									
		Continuous								Max. Continuous	Max. Intermittent
		[200]	[400]	[600]	[800]	[1000]	[1200]	[1400]	[1600]		
		14	28	41	55	69	83	97	110		[2150] 148
Flow LPM [GPM]	[2] 7,6	[257] 29 40	[554] 63 40	[847] 96 39	[1150] 130 38	[1447] 163 37	[1739] 196 36	[2035] 230 33	[2320] 262 29		[3103] 351 12
	[4] 15,1	[254] 29 81	[546] 62 81	[845] 95 80	[1145] 129 79	[1448] 164 78	[1744] 197 77	[2049] 232 76	[2343] 265 74		[3147] 356 63
	[6] 22,7	[246] 28 121	[540] 61 121	[834] 94 120	[1137] 128 120	[1434] 162 119	[1736] 196 117	[2036] 230 115	[2337] 264 112		[3151] 356 100
	[8] 30,3	[224] 25 162	[520] 59 162	[820] 93 161	[1117] 126 160	[1414] 160 159	[1716] 194 157	[2014] 228 155	[2315] 262 152		[3133] 354 140
	[10] 37,9	[202] 23 202	[499] 56 202	[793] 90 201	[1095] 124 201	[1394] 158 200	[1699] 192 198	[1997] 226 196	[2299] 260 193		[3112] 352 181
	[12] 45,4	[176] 20 243	[475] 54 242	[767] 87 242	[1063] 120 241	[1368] 155 240	[1664] 188 238	[1969] 222 236	[2268] 256 234		[3088] 349 222
	[14] 53,0	[140] 16 283	[443] 50 283	[735] 83 282	[1035] 117 281	[1340] 151 280	[1637] 185 279	[1936] 219 277	[2227] 252 274		[3051] 345 262
	Max. Continuous 56,8	[120] 14 304	[425] 48 303	[719] 81 302	[1014] 115 301	[1320] 149 300	[1618] 183 299	[1914] 216 297	[2205] 249 294		[3023] 342 283
	Max. Intermittent 75,7	[20] 3 405	[321] 36 404	[612] 69 402	[911] 103 401	[1211] 137 400	[1504] 170 398	[1795] 203 397			

		231 cm <sup>3</sup> /r [14.1 in <sup>3</sup> /r]									
		Δ Pressure Bar [PSI]									
		Continuous								Max. Continuous	Max. Intermittent
		[200]	[400]	[600]	[800]	[1000]	[1200]	[1400]	[1450]		
		14	28	41	55	69	83	97	100		[2000] 138
Flow LPM [GPM]	[2] 7,6	[338] 38 32	[707] 80 32	[1074] 121 31	[1456] 165 30	[1827] 206 30	[2192] 248 28	[2572] 291 26	[2657] 300 25		
	[4] 15,1	[328] 37 65	[695] 79 65	[1076] 122 64	[1447] 163 63	[1827] 206 62	[2201] 249 62	[2577] 291 60	[2669] 302 60		[3671] 415 50
	[6] 22,7	[317] 36 97	[687] 78 97	[1057] 119 97	[1434] 162 96	[1811] 205 95	[2186] 247 94	[2555] 289 92	[2650] 299 91		[3668] 414 80
	[8] 30,3	[289] 33 130	[659] 74 130	[1038] 117 130	[1406] 159 129	[1777] 201 128	[2160] 244 127	[2531] 286 124	[2625] 297 124		[3644] 412 112
	[10] 37,9	[265] 30 162	[631] 71 162	[1004] 113 162	[1381] 156 162	[1751] 198 160	[2131] 241 158	[2510] 284 156	[2602] 294 156		[3608] 408 145
	[12] 45,4	[230] 26 195	[599] 68 195	[968] 109 194	[1345] 152 194	[1722] 195 193	[2088] 236 192	[2480] 280 189	[2571] 290 189		[3571] 403 178
	[14] 53,0	[191] 22 227	[563] 64 227	[927] 105 227	[1299] 147 226	[1686] 190 226	[2058] 233 224	[2428] 274 222	[2519] 285 221		[3532] 399 212
	Max. Continuous 56,8	[167] 19 243	[538] 61 243	[904] 102 243	[1279] 145 242	[1661] 188 242	[2030] 229 240	[2404] 272 238	[2493] 282 238		[3488] 394 229
	Max. Intermittent 75,7	[29] 3 324	[411] 46 324	[785] 89 323	[1152] 130 322	[1520] 172 322	[1877] 212 320	[2222] 251 319	[2318] 262 318		



# H Series (101-)

## Performance Data

Motors run with high efficiency in all areas designated with a number for torque and speed, however for best motor life select a motor to run with a torque and speed range printed in the light shaded area.

Performance data is typical at 120 SUS. Actual data may vary slightly from unit to unit in production.

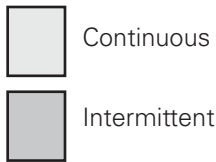

		293 cm <sup>3</sup> /r [17.9 in <sup>3</sup> /r]						Max. Continuous	Max. Intermittent
		Δ Pressure Bar [PSI]							
		[200]	[400]	[600]	[800]	[1000]	[1200]	[1350]	[1800]
		14	28	41	55	69	83	93	124
Flow LPM [GPM]	[2]	[427]	[893]	[1361]	[1829]	[2293]	[2672]	[2977]	
	7,6	48 26	101 25	154 25	207 24	259 22	302 16	336 13	
	[4]	[419]	[886]	[1362]	[1833]	[2305]	[2771]	[3110]	[4107]
	15,1	47 51	100 51	154 51	207 50	260 49	313 47	351 44	464 22
	[6]	[402]	[872]	[1342]	[1819]	[2291]	[2757]	[3098]	[4121]
	22,7	45 77	99 77	152 76	206 76	259 74	312 71	350 68	466 54
	[8]	[367]	[838]	[1316]	[1785]	[2252]	[2723]	[3070]	[4086]
	30,3	41 102	95 102	149 102	202 101	254 100	308 98	347 95	462 84
	[10]	[332]	[803]	[1276]	[1749]	[2215]	[2684]	[3034]	[4061]
	37,9	38 128	91 128	144 128	198 127	250 126	303 123	343 120	459 108
[12]	[289]	[760]	[1230]	[1706]	[2177]	[2634]	[2989]	[4012]	
45,4	33 153	86 153	139 153	193 153	246 151	298 149	338 146	453 135	
[14]	[241]	[712]	[1176]	[1650]	[2126]	[2592]	[2935]	[3963]	
53,0	27 179	80 179	133 179	186 179	240 177	293 175	332 172	448 161	
Max. Continuous	[15]	[211]	[683]	[1149]	[1623]	[2096]	[2558]	[2905]	[3914]
	56,8	24 192	77 192	130 192	183 191	237 190	289 188	328 174	442 174
Max. Intermittent	[20]	[43]	[527]	[1001]	[1463]	[1919]	[2375]	[2720]	
	75,7	5 256	60 256	113 255	165 255	217 254	268 252	307 249	

		370 cm <sup>3</sup> /r [22.6 in <sup>3</sup> /r]						Max. Continuous	Max. Intermittent			739 cm <sup>3</sup> /r [45.1 in <sup>3</sup> /r]			Max. Continuous	Max. Intermittent	
		Δ Pressure Bar [PSI]										Δ Pressure Bar [PSI]					
		[200]	[400]	[600]	[800]	[1000]	[1200]	[1250]	[1500]			[200]	[400]	[600]	[800]		
		14	28	41	55	69	83	86	103			14	28	41	55		
Flow LPM [GPM]	[2]	[537]	[1121]	[1715]	[2285]	[2862]						[2]	[1080]	[2250]	[3440]	[4570]	
	7,6	61 20	127 20	194 20	258 19	323 16						7,6	122 10	254 10	389 10	516 9	
	[4]	[532]	[1123]	[1715]	[2308]	[2893]	[3467]	[3604]	[4274]			[4]	[1070]	[2250]	[3440]	[4600]	
	15,1	60 40	127 40	194 40	261 39	327 38	392 36	407 35	483 27			15,1	121 20	254 20	389 19	520 18	
	[6]	[508]	[1100]	[1693]	[2294]	[2884]	[3458]	[3598]	[4283]			[6]	[1020]	[2200]	[3390]	[4590]	
	22,7	57 61	124 61	191 61	259 60	326 58	391 55	407 53	484 47			22,7	115 30	249 30	383 29	519 27	
	[8]	[463]	[1060]	[1661]	[2255]	[2840]	[3414]	[3557]	[4254]			[8]	[ 945]	[2135]	[3330]	[4515]	
	30,3	52 81	120 81	188 81	255 80	321 79	386 76	402 74	481 68			30,3	107 40	241 40	376 39	510 37	
	[10]	[414]	[1017]	[1613]	[2203]	[2788]	[3363]	[3506]	[4212]			[10]	[ 840]	[2050]	[3250]	[4430]	
	37,9	47 101	115 101	182 101	249 101	315 99	380 96	396 94	476 88			37,9	95 50	232 50	367 48	501 46	
[12]	[363]	[960]	[1553]	[2152]	[2737]	[3305]	[3446]	[4152]			[12]	[ 740]	[1945]	[3130]	[4320]		
45,4	41 121	108 121	175 121	243 121	309 119	373 116	389 115	469 109			45,4	84 60	220 59	354 58	488 55		
[14]	[303]	[897]	[1484]	[2086]	[2667]	[3246]	[3386]	[4092]			[14]	[ 630]	[1820]	[3005]	[4195]		
53,0	34 142	101 142	168 142	236 142	301 140	367 137	383 136	462 130			53,0	71 69	206 68	340 68	474 66		
Max. Continuous	[15]	[266]	[862]	[1452]	[2050]	[2630]	[3206]	[3347]	[4054]		Max. Continuous	[15]	[ 540]	[1735]	[2905]	[4130]	
	56,8	30 152	97 152	164 152	232 152	297 150	362 148	378 147	458 140			56,8	61 74	196 74	328 73	467 72	
Max. Intermittent	[20]	[61]	[671]	[1269]	[1847]	[2410]	[2987]	[3119]			Max. Intermittent	[20]	[ 143]	[1350]	[2565]	[3705]	
	75,7	7 202	76 202	143 202	209 202	272 202	337 199	352 198				75,7	16 99	153 98	290 97	419 96	

[862] Torque [lb-in]  
97 Nm  
152 Speed RPM



# H Series (101-)

## Dimensions

(Refer to pages B-4-19 thru B-4-22 for shaft and port dimensions.)

## Standard Rotation Viewed from Shaft End

Port A Pressurized — CW

Port B Pressurized — CCW

## Note:

Mounting surface flatness requirement is  $\nabla$ , 13 mm [.005 inch] Max.

## Note:

End ported motor pressure is derated. Reference page B-2-2 for ratings.

## 2 Bolt Flange

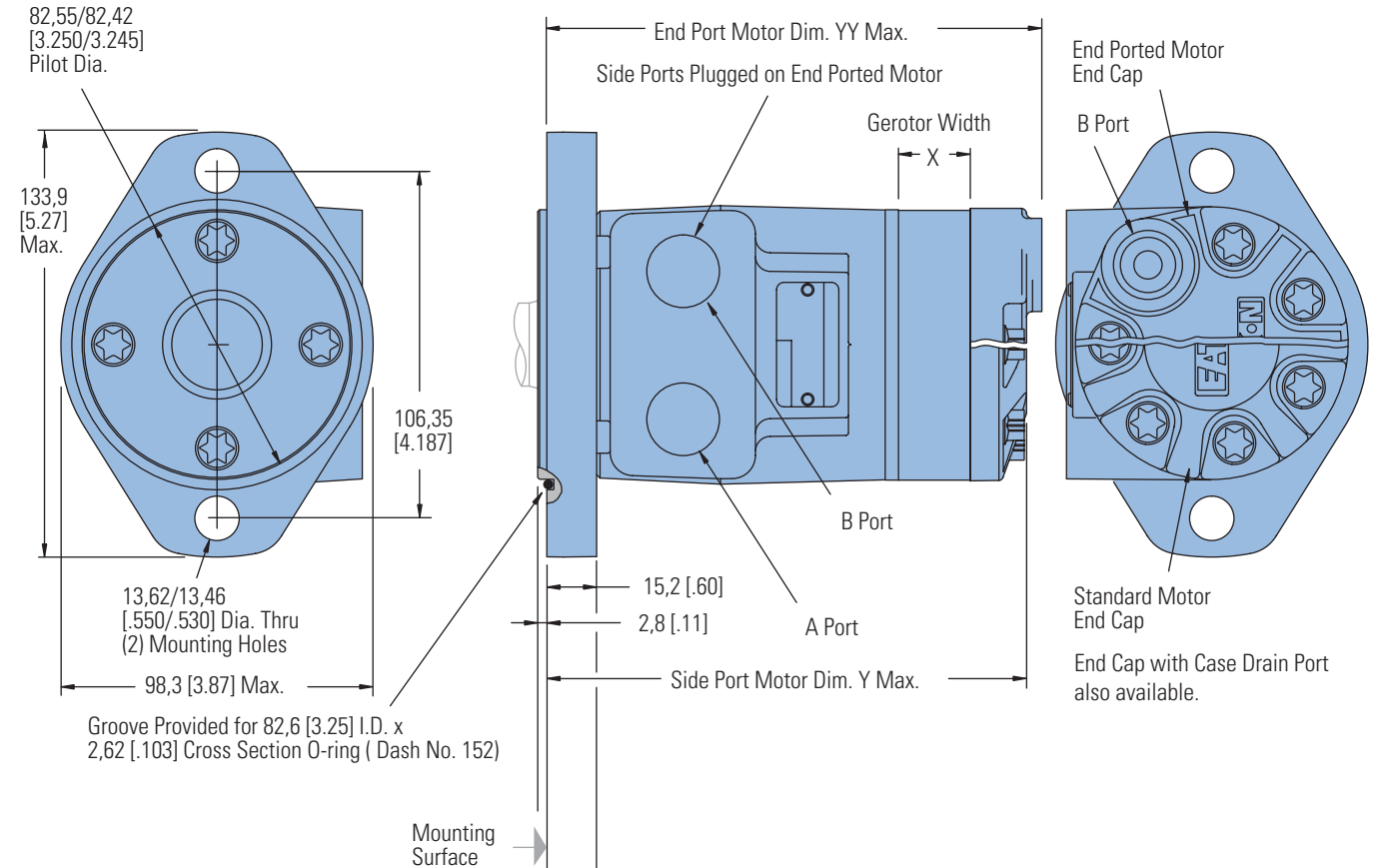

## 4 Bolt Flange

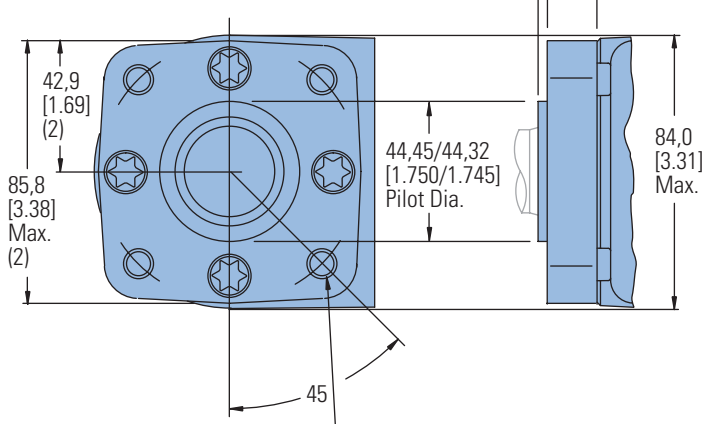

3/8-16 UNC (15,2 [.60] Max. Bolt Thread Engagement ) Mounting Holes (4) Equally Spaced on 82,6 [3.25] Dia. Bolt Circle or M10 x 1,5 (15,2 [.60] Max. Bolt Thread Engagement ) Mounting Holes (4) Equally Spaced on 82,6 [3.25] Dia. Bolt Circle

## 2 AND 4 BOLT FLANGE

Displacement cm <sup>3</sup> /r [in <sup>3</sup> /r]	X mm [inch]	Y mm [inch]	YY mm [inch]
36 [ 2.2]	6,4 [ .25]	132,1 [5.20]	138,5 [5.45]
46 [ 2.8]	6,4 [ .25]	132,1 [5.20]	138,5 [5.45]
59 [ 3.6]	10,2 [ .40]	135,9 [5.35]	142,3 [5.60]
74 [ 4.5]	10,2 [ .40]	135,9 [5.35]	142,3 [5.60]
97 [ 5.9]	13,2 [ .52]	139,0 [5.47]	145,3 [5.72]
120 [ 7.3]	16,5 [ .65]	142,3 [5.60]	148,6 [5.85]
146 [ 8.9]	20,1 [ .79]	145,8 [5.74]	152,2 [5.99]
159 [ 9.7]	21,9 [ .86]	147,6 [5.81]	154,0 [6.06]
185 [11.3]	25,4 [1.00]	151,2 [5.95]	157,5 [6.20]
231 [14.1]	31,8 [1.25]	157,5 [6.20]	
293 [17.9]	40,4 [1.59]	166,2 [6.54]	
370 [22.6]	50,8 [2.00]	176,6 [6.95]	
739 [45.1]	101,6 [4.00]	227,4 [8.95]	

# H Series (101-)

## Product Numbers

Use digit prefix —101- plus four digit number from charts for complete product number—Example 101-1001. Orders will not be accepted without three digit prefix.

### 2 Bolt Flange

SHAFT	PORT SIZE	DISPL. cm <sup>3</sup> /r [in <sup>3</sup> /r] / PRODUCT NUMBER													
		36 [ 2.2]	46 [ 2.8]	59 [ 3.6]	74 [ 4.5]	97 [ 5.9]	120 [ 7.3]	146 [ 8.9]	159 [ 9.7]	185 [11.3]	231 [14.1]	293 [17.9]	370 [22.6]	740 [45.0]	
.1 in. Straight w/Woodruff key	7/8-14 O-Ring	101-1700	-1033	-1701	-1034	-1035	-1702	-1703	-1036	-1037	-1038	-1039	-1040	—	
	1/2 NPTF	101-1704	-1025	-1705	-1026	-1027	-1706	-1707	-1028	-1029	-1030	-1031	-1032	—	
	Manifold*	101-1708	-1041	-1709	-1042	-1043	-1710	-1711	-1044	-1045	-1046	-1047	-1048	—	
1 in. SAE 6B Splined	7/8-14 O-Ring	101-1721	-1081	-1722	-1082	-1083	-1723	-1724	-1084	-1085	-1086	-1087	-1088	—	
	1/2 NPTF	101-1725	-1073	-1726	-1074	-1075	-1727	-1728	-1076	-1077	-1078	-1079	-1080	—	
	Manifold*	101-1729	-1089	-1730	-1090	-1091	-1731	-1732	-1092	-1093	-1094	-1095	-1096	—	
1 in. Straight w/ .31 Dia. Crosshole	7/8-14 O-Ring	101-1796	-1797	-1798	-1799	-1800	-1801	-1802	-1803	—	—	—	—	—	
	1/2 NPTF	101-1804	-1805	-1806	-1807	-1808	-1870	-1809	-1810	—	—	—	—	—	
	Manifold*	101-1811	-1812	-1813	-1814	-1815	-1816	-1817	-1818	—	—	—	—	—	
1 in. Straight w/ .40 Dia. Crosshole	7/8-14 O-Ring	101-1819	-1323	-1820	-1324	-1325	-1821	-1822	-1326	—	—	—	—	—	
	1/2 NPTF	101-1823	-1319	-1824	-1320	-1825	-1826	-1827	-1828	—	—	—	—	—	
	Manifold*	101-1829	-1463	-1830	-1831	-1832	-1833	-1834	-1871	—	—	—	—	—	

101-1834

### 4 Bolt Flange

SHAFT	PORT SIZE	DISPL. cm <sup>3</sup> /r [in <sup>3</sup> /r] / PRODUCT NUMBER													
		36 [ 2.2]	46 [ 2.8]	59 [ 3.6]	74 [ 4.5]	97 [ 5.9]	120 [ 7.3]	146 [ 8.9]	159 [ 9.7]	185 [11.3]	231 [14.1]	293 [17.9]	370 [22.6]	740 [45.0]	
1 in. Straight w/ Woodruff key O-Ring	7/8-14 O-Ring	101-1749	-1009	-1750	-1010	-1011	-1751	-1752	-1012	-1013	-1014	-1015	-1016	—	
	1/2 NPTF	101-1753	-1001	-1754	-1002	-1003	-1755	-1756	-1004	-1005	-1006	-1007	-1008	—	
	Manifold*	101-1757	-1017	-1758	-1018	-1019	-1759	-1760	-1020	-1021	-1022	-1023	-1024	—	
1 in. SAE 6B Splined	7/8-14 O-Ring	101-1761	-1057	-1762	-1058	-1059	-1872	-1763	-1060	-1061	-1062	-1063	-1064	—	
	1/2 NPTF	101-1764	-1049	-1765	-1050	-1051	-1766	-1767	-1052	-1053	-1054	-1055	-1056	—	
	Manifold*	101-1768	-1065	-1769	-1066	-1067	-1770	-1771	-1068	-1069	-1070	-1071	-1072	—	
1 in. Straight w/ .31 Dia. Crosshole	7/8-14 O-Ring	101-1835	-1836	-1837	-1838	-1839	-1840	-1841	-1842	—	—	—	—	—	
	1/2 NPTF	101-1843	-1497	-1844	-1449	-1352	-1845	-1846	-1847	—	—	—	—	—	
	Manifold*	101-1848	-1466	-1849	-1459	-1850	-1851	-1852	-1853	—	—	—	—	—	
1 in. Straight w/ .40 Dia. Crosshole	7/8-14 O-Ring	101-1854	-1311	-1855	-1856	-1857	-1858	-1859	-1860	—	—	—	—	—	
	1/2 NPTF	101-1861	-1313	-1862	-1312	-1314	-1863	-1864	-1315	—	—	—	—	—	
	Manifold*	101-1865	-1305	-1866	-1306	-1307	-1867	-1868	-1869	—	—	—	—	—	

101-1868

### 4 Bolt Flange with Corrosion Protection

SHAFT	PORT SIZE	DISPL. cm <sup>3</sup> /r [in <sup>3</sup> /r] / PRODUCT NUMBER													
		36 [ 2.2]	46 [ 2.8]	59 [ 3.6]	74 [ 4.5]	97 [ 5.9]	120 [ 7.3]	146 [ 8.9]	159 [ 9.7]	185 [11.3]	231 [14.1]	293 [17.9]	370 [22.6]	740 [45.0]	
1 in. Straight w/ Woodruff Key	1/2 NPTF	101-2032	-2014	-2093	-2027	-2013	-2094	-2095	-2015	-2028	-2029	-2030	-2031	—	
	Manifold*		-2067							-2068	-2069				

\*Manifold product numbers shown are for motors with four 5/16-18 port face mounting threads. Manifold, manifold mounting O-Rings and bolts are NOT included.

For H Series Motors with a configuration Not Shown in the charts above: Use the model code system on page B-2-11 to specify the product in detail.

# H Series (101-)

## Model Code

The following 30-digit coding system has been developed to identify all of the configuration options for the H motor. Use this model code to specify a motor with the desired features. All 30-digits of the code must be present when ordering. You may want to photocopy the matrix below to ensure that each number is entered in the correct box.

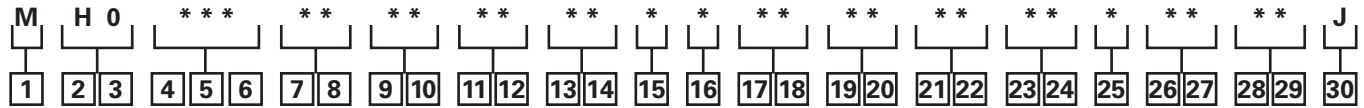

### 1 Product

M - Motor

### 2, 3 Series

H0 - H Motor

### 4, 5, 6 Displacement cm<sup>3</sup>/r [in<sup>3</sup>/r]

- 022 – 36 [2.2]†
- 028 – 46 [2.8]
- 035 – 58 [3.5]†
- 045 – 74 [4.5]
- 059 – 96 [5.9]
- 073 – 120 [7.3]
- 089 – 146 [8.9]
- 097 – 159 [9.7]
- 113 – 185 [11.3]
- 141 – 231 [14.1]
- 179 – 294 [17.9]
- 226 – 370 [22.6]
- 451 – 739 [45.1]†

†The H Series motors with the displacement code "022," "035," or "451" must also specify free running gerotor. (Option "A" in position 15).

### 7, 8 Mounting Type

**A – 2 Bolt (Standard) 82.50 [3.248] Dia. x 3.05 [.120] Pilot, 13.59 [.535] Dia. Mounting Holes on 106.35 [4.187] Dia. B.C.**

**BA – 4 Bolt (Standard) 44.40 [1.748] Dia. x 3.05 [.120] Pilot, .375-16 UNC-2B Mounting Holes on 82.55 [3.250] Dia. B.C.**

CA – 2 Bolt (Standard) 82.50 [3.248] Dia. x 6.10 [.240] Pilot, 10.41 [.410] Dia. Mounting Holes on 106.35 [4.187] Dia. B.C. (SAE A)

DD – 2 Bolt (Standard) 101.60 [4.000] Dia. x 6.10 [.240] Pilot, 14.35 [.565] Dia. Mounting Holes on 146.05 [5.750] Dia. B.C. (SAE B)

**FA – 4 Bolt (Standard) 44.40 [1.748] Dia. x 3.05 [.120] Pilot, M10 x 1.5-6H Mounting Holes on 82.55 [3.250] Dia. B.C.**

MA – 2 Bolt (Standard) 82.50 [3.248] Dia. x 8.13 [.320] Pilot, 13.59 [.535] Dia. Mounting Holes on 106.35 [4.187] Dia. B.C., w/o O-ring Groove

### 9, 10 Output Shaft

**01 – 25.4 [1.00] Dia. Straight, Woodruff Key, .250-20 UNC-2B Hole in Shaft End**

**02 – 25.4 [1.00] Dia. SAE 6B Spline, .250-20 UNC-2B Hole in Shaft End**

07 – 25.4 [1.00] Dia. Straight, 8.03 [.316] Dia. Cross Hole 11.2 [.44] from End, 5.6 [.22] Extra Length

**08 – 25.4 [1.00] Dia. Straight, 10.31 [.406] Dia. Cross Hole 15.7 [.62] from End, .250-20 UNC-2B Hole in Shaft End**

**16 – 22.22 [.875] Dia. SAE 13 Tooth Spline (SAE B)**

17 – 22.22 [.875] Dia. Straight, 6.4 [.25] x 19.0 [.75] Square Key (SAE B)

18 – 25.4 [1.00] Dia. Tapered, Woodruff Key and Nut, 34.92 [1.375] Taper Length

**24 – 25.00 [.984] Dia. Straight, 8.00 [.315] KEY, M8 x 1.25-6H Hole in Shaft End**

39 - 25.00 [.984] Dia. Straight (k6), 8.00 [.315] Key, M8 x 1.25-6H Hole in Shaft End

### 11, 12 Ports

**AA – .875-14 UNF-2B SAE O-Ring Ports**

**AB – .500-14 NPTF Dry Seal Pipe Thread Ports**

**AC – Manifold Ports (.3125-18 UNC-2B Mounting Holes)**

AD – Manifold Ports (M8 x 1.25-6H Mounting Holes)

**AF – G 1/2 BSP Straight Thread Ports**

EB†† – End Ports: .750-16 UNF-2B SAE O-Ring Ports

EC†† – End Ports: G 1/2 BSP Straight Thread Ports

†† Note: End ported motor pressure is derated. Reference page B-2-2 for ratings.

### 13, 14 Case Flow Options

00 – None

**01 – .4375-20 UNF-2B SAE O-Ring Port (End Cap)**

**02 – G 1/4 BSP Straight THD Port (End Cap)**

**03 – Manifold case drain**

04 – .4375-20 UNF-2B SAE O-ring port (side of housing)

05 – .3125-24 UNF-2B SAE O-ring port (mounting flange)

**11 – Internal Check Valves**

### 15 Gerotor Options

0 – None

A – Free Running

### 16 Shaft Options

0 – None

N – Electroless Nickel Plated

### 17, 18 Seal Options

**00 – Standard Seals**

02 – Seal Guard

03 – Viton Seals

**04 – Viton Shaft Seal**

**07 - High Pressure Shaft Seal**

11 – High pressure shaft seal, slinger seal

**19 – Extreme duty seal guard**

### 19, 20 Speed Sensor Options

00 – None

AA – 12mm digital speed pickup (15 pulse) without lead wire

AB – Magnetic Speed Pickup (60 Pulse by Quadrature), No Lead Wire with M12 Connector (A=Power, B=Common, C=Signal)

### 21, 22 Valve Options

00 – None

\* – Contact your Eaton Sales Representative for available options.

### 23, 24 Special Features (Hardware)

00 – None

AB – Low Speed Valving

SS – Stainless Steel Flange Bolts

### 25 Special Assembly Instructions

0 – None

1 – Reverse Rotation

2 – Flange Rotated 90°

### 26, 27 Paint/ Special Packaging

00 – No Paint

**AA – Low Gloss Black Primer**

AD – Environmental Coated Gloss White

AF – Environmental Coated Black

### 28, 29 Eaton Assigned Code when Applicable

00 – Assigned Code

### 30 Eaton Assigned Design Code

J – Nine (9)

Feature in **bold** are preferred and allow for shorter lead time.